

VALEZUS

T1200

This guide describes total operation features and specifications.

User's Guide



CAUTION

Be sure to read this guide prior to use.

After reading this guide, keep it in handy for future reference.

About This Guide

Preface

Thank you for purchasing the VALEZUS T1200.

The VALEZUS T1200 is a network-compatible high-speed color printer that uses inkjet technology.

The machine comes with oil-based ink excellent in color performance. Five colors of ink, cyan, magenta, yellow, black, and gray are used to reproduce smooth expression of gradations.

Besides, the machine provides various functions such as output of data from a computer, management of the printer, and high capacity feeding or stacking.

The following manuals are included with this machine.

● **User's Guide (this guide)**

This guide describes handling precautions and specifications, as well as the operations and settings of each function.

Read this guide for a more detailed understanding of the machine.

● **Administrator's Guide**

This guide describes the settings of the machine and dedicated equipment to be configured by the administrator.

● **Troubleshooting Guide**

This guide describes the actions to take when a paper jam or other problem occurs.

About This Guide

(1) This guide may not be reproduced in whole or in part without the permission of RISO KAGAKU CORPORATION.

(2) The contents of this manual may be changed without prior notice due to product improvements.

(3) RISO KAGAKU CORPORATION shall not be liable for any consequence of using this guide or the machine.

Trademark Credits

Windows is either a registered trademark or a trademark of Microsoft Corporation in the United States and/or other countries.

PostScript is either a registered trademark or a trademark of Adobe in the United States and/or other countries.

 **RISO**, VALEZUS and FORCEJET are trademarks or registered trademarks of RISO KAGAKU CORPORATION in the United States and other countries.

Other corporate names and/or trademarks are either registered trademarks or trademarks of each company, respectively.

Symbols, Notations, and Screenshots Used in This Guide

■ Symbols Used in This Guide



Indicates cautions that should be noted for safe use of this machine.



Indicates important items that should be noted or are prohibited.



Indicates useful or additional information.

■ Names of Keys and Buttons

The following names are indicated with square brackets []:

- The names of hard keys on the operation panel
- The names of buttons/items on the touch panel
- The names of buttons/items on the computer window

Example: Press the [Stop] key.

■ Names of Dedicated Equipment

In this guide, the names of the dedicated equipment are described using a generic term as shown below. The specific name for each item of equipment is used when its unique features are explained.

Name Used in This Guide	Dedicated Equipment
Standard tray	High capacity feeder
	Double tray feeder (Feed 1, Feed 2)
Stacking tray*	High capacity stacker
	Double tray stacker (Unit 1, Unit 2)

* The stacking tray connected to the right side of the machine.

■ Illustrations and Operating Procedures in This Guide

- The procedures, screen shots, and illustrations in this guide assume that the high capacity feeder and high capacity stacker are connected. This guide also assumes that each function is set to the factory setting.
- The screenshots and illustrations in this guide may vary depending on the usage environment including connected equipment.

Contents

About This Guide	1
Symbols, Notations, and Screenshots Used in This Guide	2
Safety Precautions	5
Warning Symbols	5
Power Plug	5
Installation Location	5
Power Connection	6
Ground Connection	6
Handling	6
Ink Cartridge	7
Before Use	8
Installation Location	8
Power Connection	8
Required Spacing	9
Handling	11
Printable Area	11
Printing Paper	12
Printouts	14
Materials Not to Be Printed	14
Ink Cartridge Storage and Handling Precautions	14
Disposing of Used Ink Cartridges and Cleaning Tanks	15
Part Names and Functions	16
Main Unit	16
Operation Panel	17
Touch Panel	19
[Home] Screen	19
[Admin Menu] Screen	20
[Maintenance] Screen	20
[System Info] Screen	20
Touch Panel	23
Preparation	25
Power	25
Loading the Paper	25
System Configuration	29
About Jobs	31
[Active / Idle] Screen	31
[Finished] Screen	31
[Paper info] Screen	32
Printing	33
Sending Print Data	33
Dedicated Equipment	34



High Capacity Feeder	34
High Capacity Stacker	38
Double Tray Feeder	43
Double Tray Stacker	48
Appendix	53
Maintenance	53
About Ink Cartridges	54
Specifications	56
Consumables	63

Safety Precautions





This section describes the items that should be followed for safe use of this machine. Be sure to read this section before using the machine.

Warning Symbols

To use the machine properly and to prevent human injury and damage to properties, the following warning symbols are used. Read the meaning of the symbols to understand and then read this guide.

 WARNING	Indicates that incorrect handling by ignoring this symbol may cause death or serious human injury.
 CAUTION	Indicates that incorrect handling by ignoring this symbol may cause human injury or damage to properties.

Examples of symbols

	The  symbol indicates a prohibited action. A specific prohibited action is drawn inside or next to the symbol. (The left figure indicates that disassembly is prohibited.)
	The  symbol indicates a forced action or an instruction. A specific instruction is drawn inside the symbol. (The left figure indicates an instruction to remove the power plug from the electrical outlet.)

Power Plug

- The main unit and dedicated equipment connected to the main unit have power plugs.



Installation Location

CAUTION

- Place the machine on a flat or stable surface. Otherwise, the machine might be inclined or fall down, resulting in human injury.
- The machine has ventilation openings. Place the machine at least 100 mm (3 15/16") from walls. If the ventilation openings are blocked, the inside of the machine may become hot and a fire might occur.
- Do not place the machine in a dusty or humid location. Otherwise, a fire or an electric shock might occur.

Power Connection

WARNING

- Install the machine near the wall socket to avoid using an extension cord between the machine and the wall socket. If an extension cord is absolutely required, do not use longer than 5m (15ft). Otherwise, a fire or an electric shock might occur. 
- Do not damage or rebuild the power cord. Placing a heavy object on the cord or pulling or forcibly bending the cord may damage the cord, resulting in a fire or an electric shock. 
- The power cord supplied with this product can be used only for this machine. Do not use it for another electric product. Otherwise, a fire or an electric shock might occur.
- Do not plug or unplug the power cord if your hands are wet. Otherwise, an electric shock might occur.

CAUTION

- Connect the plug securely to the electrical outlet to avoid a loose connection.
- Do not pull the power cord when unplugging it. Otherwise, it could become damaged and a fire or an electric shock might occur. Be sure to hold on to the plug when unplugging the power cord.
- If the machine will not be used for a long time, such as during a holiday, unplug the power cord from the electrical outlet for safety.
- Pull out the power plug from the electrical outlet at least once a year and clean the prongs of the plug and their surroundings. Dust collected on these areas can result in fire.



Ground Connection

WARNING

- Be sure to insert the power plug with a ground conductor into the wall outlet with a ground receptacle. Do not use the machine if it is not grounded. It may result in fire or electric shock. 

Handling

WARNING

- Do not place water containers or metallic objects on the machine. If water drips inside the machine or a metallic object drops inside it, a fire or an electric shock might occur.
- Do not remove the covers. Otherwise, you might be electrically shocked by the high-voltage part inside. 
- Do not disassemble or rebuild the machine by yourself. Otherwise, a fire or an electric shock might occur.
- Do not insert or drop any metallic material or flammable substances into the machine through any opening. A fire or an electric shock might occur.
- If something drops inside the unit, immediately press and hold the [Power] key to turn off the power for operations, then turn off the main power switch. Next, unplug the power cord and contact your dealer or authorized service representative. Continued use might result in a fire or an electric shock. 
- If the unit emits excessive heat, smoke or foul odor, immediately press and hold the [Power] key to turn off the power for operations, then turn off the main power switch. Next, unplug all the power cords and contact your dealer or authorized service representative. Otherwise, a fire or an electric shock might occur. 

CAUTION

- Do not insert your fingers in the areas around the standard tray or stacking tray. Otherwise, an injury might occur.
- Do not touch the moving parts of the machine. Otherwise, an injury might occur.
- Be careful of protruding parts and metal terminals when inserting the hand inside the printer such as removing jammed paper. Otherwise, an injury might occur.
- The inside of the printer may have areas with ink. Be careful not to let the ink come in contact with your hands or clothing. Should ink accidentally make contact with your hands, wash it off with detergent as soon as possible.
- When moving the machine, contact your dealer or authorized service representative. If you try to forcibly move the machine, the machine may overturn, resulting in injury.
- When using the double tray feeder



Caution! A finger is caught.

Do not put your fingers in the opening in the main body of the double tray feeder. Doing so may result in your fingers being caught while the double tray feeder moves.



Caution! Hot surface

Since the parts near the high temperature caution label may be heated and cause burns, do not touch the parts directly with your fingers.

Ink Cartridge

CAUTION

- Avoid contact to eyes and/or skin. If ink gets into your eyes, flush it out immediately with plenty of water. If ink comes into contact with your skin, wash it off thoroughly using soap.
- Allow plenty of ventilation during printing. Seek fresh air immediately if you feel unwell during use.
- If you feel sick, seek medical advice immediately.
- Use the ink only for printing purposes.
- Do not dispose of used ink cartridges by burning. The ink is combustible and can cause the fire to grow, resulting in burns.
- Store ink cartridges out of the reach of children.
- The ink is a combustible liquid. In the event of fire, use potassium carbonate mist, foam, powder, or a carbon dioxide fire extinguisher.

Before Use

This section describes the precautions that must be observed before using the machine.

Installation Location

Observe the following precautions.

- **Your dealer will help you to determine a proper location for the machine at the time of delivery.**
- **When moving the machine, contact your dealer or authorized service representative.**
- **Avoid installing the machine in the following locations. Otherwise, incorrect operation, malfunction, or accident might occur.**
 - Places subject to direct sunlight or excessively illuminated such as next to windows (if inevitable, use a curtain at the window)
 - Places subject to sudden temperature variations
 - Places excessively hot and humid or cold and dry
 - Places close to fire or heat
 - Places directly subject to cold air from air conditioners or hot air from heaters, as well as radiant heat
 - Places with poor air permeability or ventilation
 - Dusty places
 - Places subject to excessive vibration
- **Install the machine in a place whose levelness is within the following specified range.**
Installation surface level: 2° or less
- **Operate the machine under the following environment conditions.**
Temperature range: 15 °C - 30 °C (59 °F - 86 °F)
Humidity range: 40% - 70% RH (non-condensing)

Power Connection

Observe the following precautions.

- **Connect the plug securely to the electrical outlet to avoid a loose connection. You may have two or more power plugs if you have dedicated equipment connected.**
- **Install the machine near an electrical outlet.**

Required Spacing

Provide sufficient space for the machine operations, replacing the consumables, and maintenance.

■ High Capacity Feeder, Printer, and High Capacity Stacker

- As seen from the front

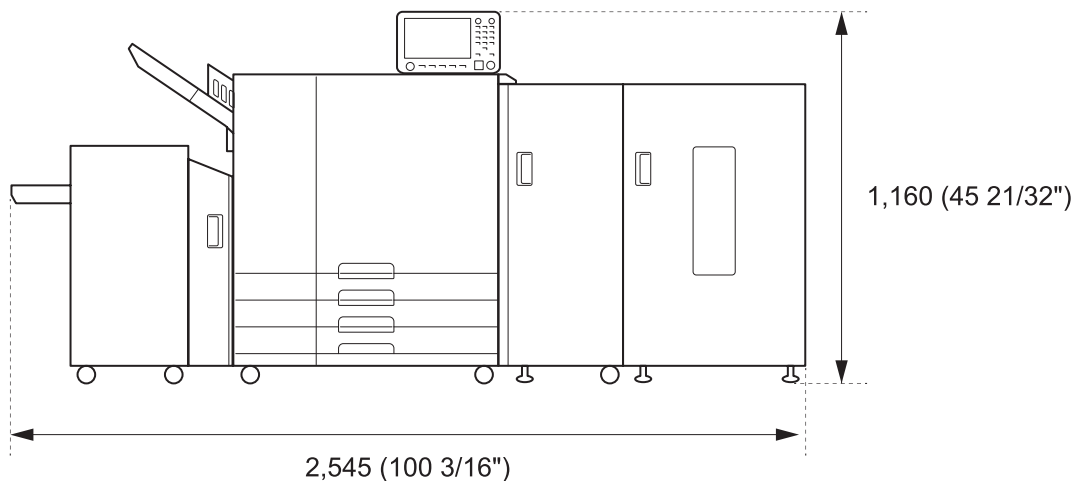

The width is 2,555 mm (100 19/32") when covers and operation parts are open.

Units: mm (inch)

- As seen from the side

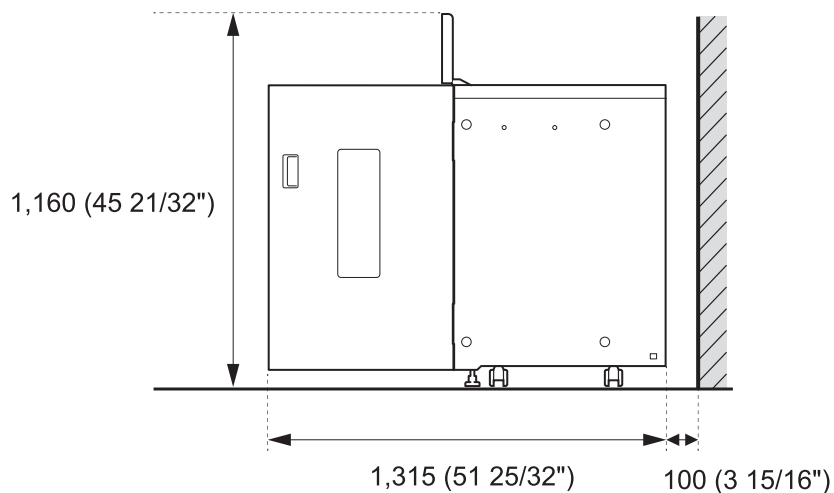

Units: mm (inch)

■ Double Tray Feeder, Printer, and Double Tray Stacker

- As seen from the front

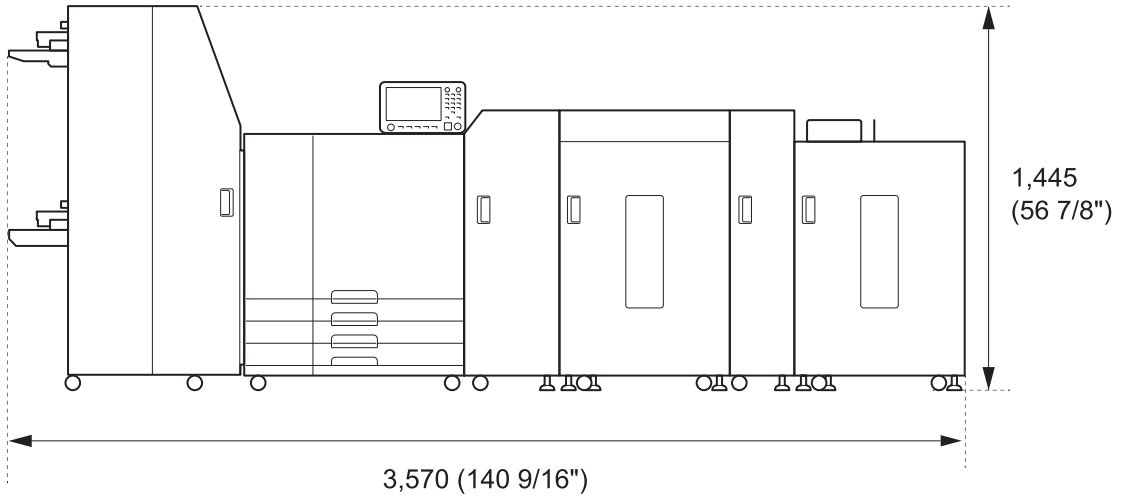

The width is 3,760 (148 1/32") when covers and operation parts are open.

Units: mm (inch)

- As seen from the side

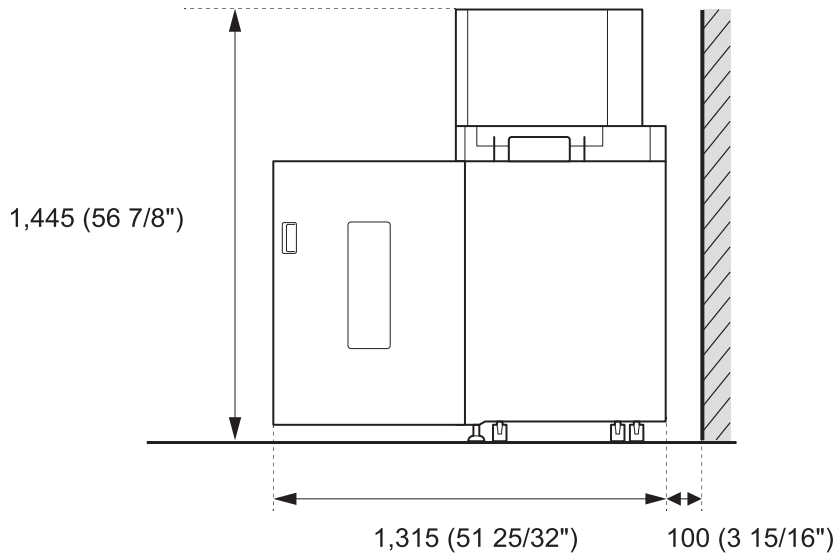

Units: mm (inch)

Handling

- Do not use the main power switch to turn off the machine or unplug the machine during operation.
- Do not open any of the covers during operation.
- Do not move the machine.
- The machine contains precision components and moving parts. Therefore, do not perform operations not described in the guides.
- Do not place heavy objects on the machine or subject the machine to strong shocks.
- Open and close the covers gently.
- After turning off the main power switch, wait until the [Main Power] LED goes off before turning on the main power switch again.
- Perform head-cleaning if the machine will not be used for a long time or before using the machine after a long period of non-use. Ink may deteriorate or dry up in the ink feed path inside the machine, resulting in clogging of the print head. It is recommended that head-cleaning be performed regularly to prevent this from occurring.
- Do not touch the print head, as this can result in malfunction or deterioration in print quality.
- Always keep all the color ink cartridges in the machine. Do not leave the machine with the ink cartridges removed, even when not using the machine.

Printable Area

Maximum Print Area

Printable Area	314 mm × 458 mm (12 11/32" × 18 1/32")
Printable Area (Margin)	Standard: 3 mm (1/8") Maximum: 1 mm (3/64")



- Printing without margins cannot be performed. Margins are always added around the edges of the paper.

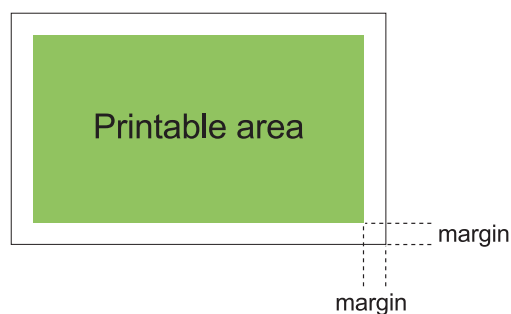

Some areas around the edges of the paper cannot be printed regardless of the data size of the original.

- Depending on the content of the original, text or images may be lost or bleeding may occur.
- Even when the paper size is within the maximum print area, a margin is always provided.

Printable Area of Envelopes

The following envelopes of the standard size can be printed on this machine:

- C4: 229 mm × 324 mm (9" × 12 3/4")
- C5: 162 mm × 229 mm (6 3/8" × 9")
- C6: 114 mm × 162 mm (4 1/2" × 6 3/8")
- DL R: 110 mm × 220 mm (4 11/32" × 8 21/32")
- Envelope 229 mm × 305 mm (9" × 12")
- Envelope 254 mm × 331 mm (10" × 13")
- NO.10 envelope 105 mm × 242 mm (4 1/8" × 9 1/2")

To print on the envelopes of the non-standard size, you need to register the paper size using [Custom Paper Entry] on the administrator menu in advance. Contact your administrator.

The printable area on envelopes is the area enclosed within 10 mm (13/32") of the edges of the envelope.

Any part of the image that does not fit within the printable area is not printed.

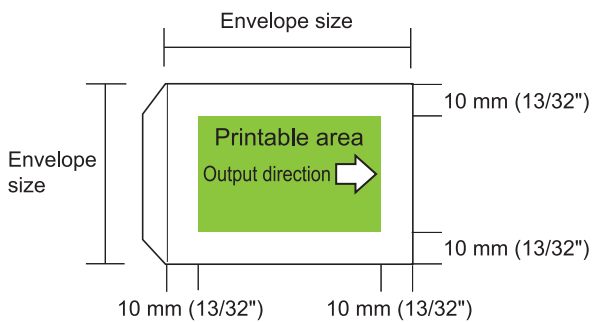

- When printing on envelopes, it is recommended using the stacking tray.
- To also print on the flap section, you must register the envelope size including the flap section.
- You cannot use duplex print when printing on envelopes.

Printing Paper

■ If you use paper that is not compatible with this machine, it may result in problems such as paper jamming, soiling or malfunctions.

■ For paper which can be loaded in the feed tray and standard tray, their specifications are different.

Paper Basic Specifications

Feed Tray

Size	182 mm × 182 mm - 297 mm × 432 mm (7 3/16" × 7 3/16" - 11 11/16" × 17")
Weight	52 g/m ² - 104 g/m ² (14-lb bond - 28-lb bond) Ream weight: 45 kg - 90 kg (99 lb - 198 lb) (duodecimo)
Paper Type	Plain paper, recycled paper
Maximum Load	Height up to 56 mm (2 3/16") in each tray

High Capacity Feeder

Size	90 mm × 148 mm - 340 mm × 460 mm (3 9/16" × 5 13/16" - 13 3/8" × 18 1/8")
Weight	46 g/m ² - 210 g/m ² (12-lb bond - 56-lb bond) Ream weight: 40 kg - 180 kg (88 lb - 397 lb) (duodecimo)
Paper Type	Plain paper, recycled paper, envelopes, postcards (plain paper), postcards (inkjet)
Maximum Load	Height up to 440 mm (17 5/16")

Double Tray Feeder

Size	148 mm × 210 mm - 330.2 mm × 460 mm (5 13/16" × 8 1/4" - 13" × 18 1/8")
Weight	46 g/m ² - 210 g/m ² (12-lb bond - 56-lb bond) Ream weight: 40 kg - 180 kg (88 lb - 397 lb) (duodecimo)
Paper Type	Plain paper, recycled paper
Maximum Load	Height up to 440 mm (17 5/16") (2 trays)

■ **Acceptable paper sizes depend on the output tray.**

Paper sizes for output trays

Face down tray	90 mm × 148 mm - 340 mm × 460 mm (3 9/16" × 5 13/16" - 13 3/8" × 18 1/8")* ¹
High Capacity Stacker	When printouts are not collated: 90 mm × 148 mm - 340 mm × 460 mm (3 9/16" × 5 13/16" - 13 3/8" × 18 1/8")* ² When offset output is applied: 90 mm × 182 mm - 340 mm × 432 mm (3 9/16" × 7 3/16" - 13 3/8" × 17")* ³
Double Tray Stacker	When printouts are not collated: 148 mm × 210 mm - 330.2 mm × 460 mm (5 13/16" × 8 1/4" - 13" × 18 1/8")* ² When offset output is applied: 148 mm × 210 mm - 330.2 mm × 432 mm (5 13/16" × 8 1/4" - 13" × 17")* ³

*1 Envelopes are not acceptable.

*2 Height up to 440 mm (17 5/16")
Height up to 110 mm (4 11/32") for A5, postcards, envelopes, or non-regular size paper when using the high capacity stacker
Height up to 110 mm (4 11/32") for A5 or non-regular size paper when using the double tray stacker

*3 Height up to 405 mm (15 15/16")
Not applicable to A5, postcards, envelopes, or non-regular size paper when using the high capacity stacker
Not applicable to A5 or non-regular size paper when using the double tray stacker



• Depending on the type of paper, operating environment, and storage conditions, even paper meeting these size and weight specifications may not be able to pass through the machine in some cases.

■ **Do not use the following paper types as they will cause problems such as paper jamming or malfunctions.**

- Paper that does not comply with the conditions in the basic specifications
- Paper with a processed surface, such as thermal paper or carbon paper
- Curled paper (3 mm (1/8") or more)
- Paper with wrinkles
- Bent paper
- Torn paper
- Paper with ripples
- Coated paper such as art paper

- Paper with jagged edges
- Glued paper
- Paper with holes
- Glossy paper for photographs
- Transparencies
- Yupo paper

■ **Always use paper from a sealed package.**

■ **After finishing the print job, return the unused paper from the standard tray to the package and store. If you leave the paper in the standard tray, the paper may curl and cause paper jamming. (It is recommended to take necessary sheets out of the wrapping paper and load them to the standard tray.)**

■ **If the paper is not cut cleanly or has a textured surface (such as drawing paper), fan the paper before use.**

■ **Store paper flat, away from high temperatures, high humidity, and direct sunlight.**

Printouts

- When using duplex printing, the edges of the paper may become dirty depending on the original.
- Printouts lose their color (discolor) over time due to various chemicals in the air and light. You can protect printouts against discoloration by allowing the printout to fully dry and then inserting it into a glass frame or laminating it.
- When storing printouts in a clear file folder, be sure to use only those made of polyethylene terephthalate (PET).
- Printouts can lose color when they come in contact with water or sweat. Avoid storing printouts in a place subject to moisture. Writing on printouts with an oil-based pen can cause bleeding.
- The print density of the printout immediately after printing differs from the print density 24 hours later.
Print density decreases over time.
- Do not place printouts from this machine on top of printouts from a laser printer or copier that uses toner.
The paper might stick to the printed toner and the toner might transfer to the printout.
- Do not place printouts from this machine on or beneath the thermal paper or pressure-sensitive paper. Image on the thermal paper or pressure-sensitive paper might lighten or vanish.
- The printouts include very small quantities of volatile components. When printouts are left on a place such as on a desk, in rare cases it may look as if the volatile components may have transferred on to that item. However, they will evaporate and disappear over time.

Materials Not to Be Printed

- Do not use the machine in any manner which violates the law or infringes on established copyrights, even when making copies for personal use. For more information, contact your dealer or authorized service representative. In general, use discretion and common sense.

Ink Cartridge Storage and Handling Precautions

The ink cartridges for this machine are partly made of paper. For this reason, cartridges may become deformed and unusable if stored incorrectly or in an unsuitable environment. Store the ink cartridges properly, according to "Storage".

Storage

- When storing the ink cartridge, keep the ink cartridge in the original package, and store it horizontally in the direction indicated by the this-side-up mark.
- Avoid freezing or placement under direct sunlight. Store in areas between 5 °C and 35 °C (41 °F - 95 °F).
Do not store in locations subject to extreme changes in temperature.
- If the plastic bag is opened but the ink cartridge is not to be used right away, store the ink cartridge properly and insert it into the machine as soon as possible.

Handling Precautions

- Do not shake the ink cartridge. This can create bubbles, resulting in a deterioration in print quality.
- Do not add ink into the ink cartridge.
- Remove the ink cartridge from its plastic bag just before inserting it into the machine.

- Adequate operation temperature is 15 °C - 30 °C (59 °F - 86 °F).
Using the ink cartridge outside the adequate operation temperature range can result in a deterioration in print quality (reduced ink discharge).
The spraying properties of the inkjet printer can vary depending on the ink viscosity. In particular, at lower temperatures, the ink viscosity increases and can result in clogging of the print head. Follow the information on the operation environment and storage temperature, check the manufacturing date, and use the ink cartridge within 24 months from the date of manufacture.
- If the cap of the ink cartridge is removed and the ink cartridge is left for a long period of time without being used up, various chemicals in the air can cause the ink cartridge to deteriorate.
Using ink that has deteriorated or changed in quality can damage the print head or ink flow path.
- Do not dump the ink left in the cartridge into the sewers.
- The ink is a combustible liquid.
In the event of fire, use potassium carbonate mist, foam, powder, or a carbon dioxide fire extinguisher.

Disposing of Used Ink Cartridges and Cleaning Tanks

- The ink in the cleaning tank cannot be used for printing.

Part Names and Functions

Main Unit



• For part names and functions other than the main unit, see "Dedicated Equipment" (p.34).

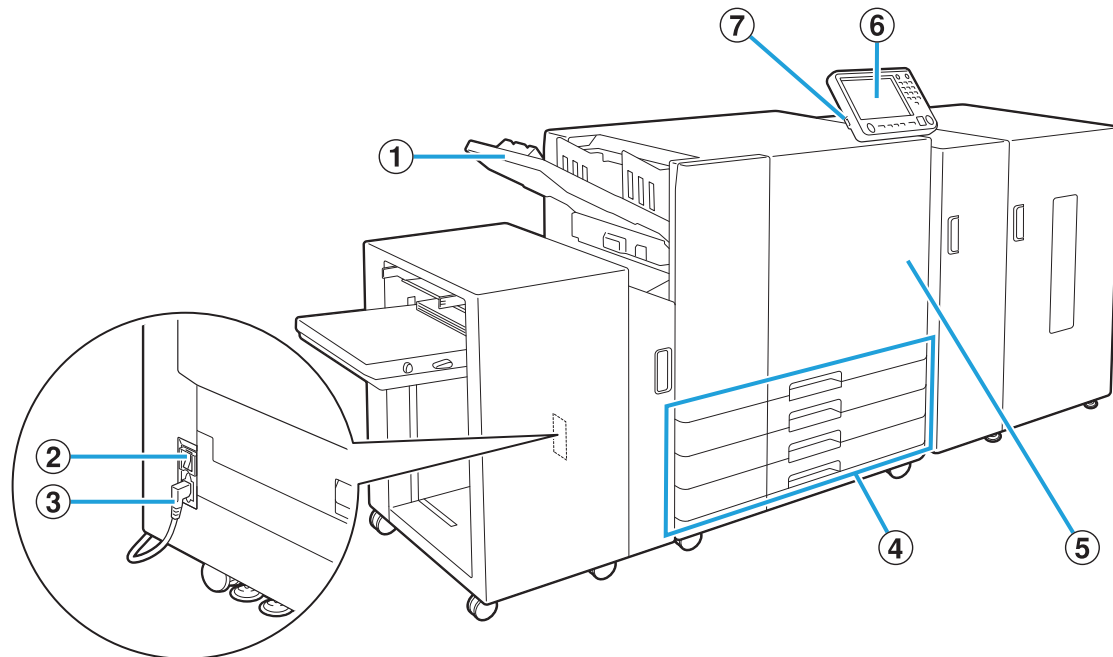

① Face Down Tray

Printouts are output face down.



• The face down tray is not available when the double tray feeder is connected.

② Main Power Switch

Use this switch to turn on the power. Usually the power is left ON.

③ Main Unit Socket

Connect the main unit power cable to this socket.

④ Feed Tray 1, Feed Tray 2, Feed Tray 3 (Feed Trays)

Load the paper to be used for printing here.



• Use the standard tray for thick paper and other special paper types.

⑤ Front Cover

Normally the front cover is locked and cannot be opened. This lock is automatically released when a paper jam or other problems occur.

To open the front cover in other cases, go to [Maintenance] from the [Home] screen and touch [Front Cover Release].

⑥ Operation Panel

Use to perform operations or settings. You can adjust the angle so that it is easier to see.

⑦ USB Port

Connect a USB flash drive to this port to save account record history files.



• You need to use the USB flash drives compatible with Mass Storage Class and file system format (FAT16, FAT32, exFAT).

Operation Panel

Various operations and settings can be performed using the operation panel. The color and condition (light up or flashing) of the LEDs indicate the machine status or errors such as paper jams.

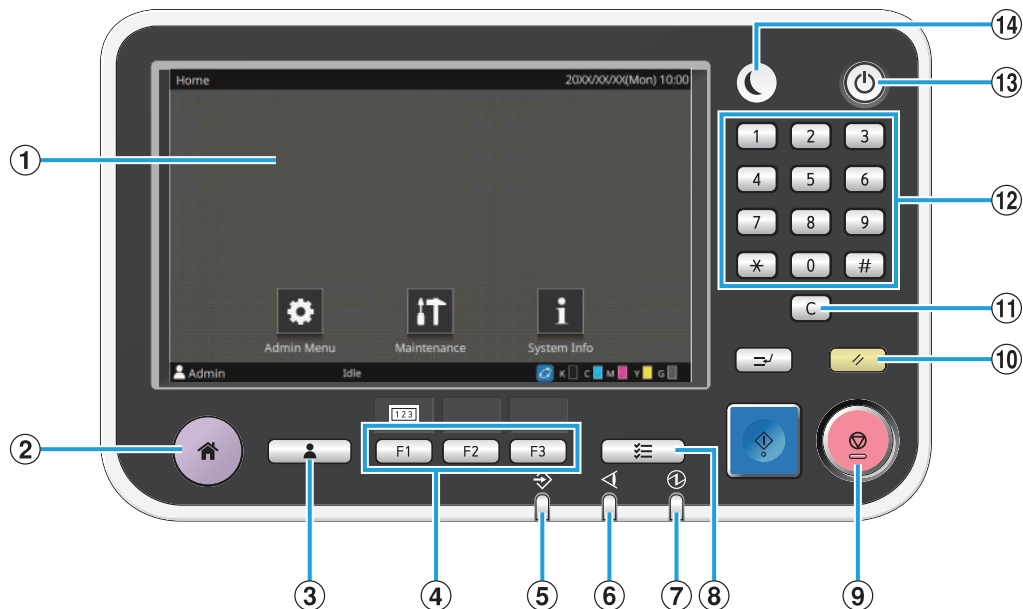

① Touch Panel

Use to perform operations or settings. This panel also displays information such as error messages and confirmation messages.

Depending on the screen or list, flick operations may be available by flicking your finger in a certain direction on the touch panel.

(p.19 "Touch Panel")

② Home Key

Press this key to bring up the [Home] screen.

③ Login / Logout Key

Press this key to log in or log out.

④ Function Keys

You can preset frequently used functions and settings. Use these keys as shortcut keys.



- For specific instructions on how to register functions and settings, contact your administrator.

⑤ Data LED

This LED lights up when there is a job waiting and flashes when this machine is receiving data.

⑥ Error LED

This LED flashes when an error occurs.

⑦ Main Power LED

This LED lights up when the main power is on.

⑧ Job Status Key

Press this key to check jobs that are in progress or finished.

⑨ Stop Key

Press this key to stop the job that is in progress.

⑩ Reset Key

Press this key to return the settings to their default values.



- Only selected settings are reset. The other settings remain unchanged by this operation.

⑪ Clear Key

Press this key to clear letters or numbers that have been entered.

⑫ Numeric Keys

Use these keys to enter numbers.

⑬ Power Key

When you press this key while the main power is on, the operation power turns on and this key lights up. Holding it turns off the operation power, and the machine goes into stand-by mode.

⑭ Wake Up Key

This key lights up when this machine is in power saving mode. Pressing this key when it is lit makes the machine ready for operation.



- Pressing this key when it is not lit makes the machine go into sleep mode.
-

Touch Panel

[Home] Screen

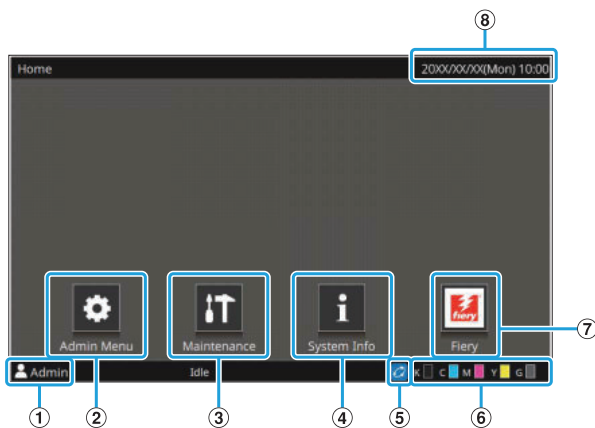

The [Home] screen appears when you press the [Home] key in the operation panel. To access the settings and operations, touch the button that you want to use.



- The screen displayed varies depending on the connected equipment and settings.

① User Name

The name of the user currently logged in is displayed.

② [Admin Menu] Button

Touch this button to access the administrator settings.



- This button does not appear when the user is not logged in as an administrator.

③ [Maintenance] Button

Touch this button to access maintenance features.

④ [System Info] Button

Touch this button to display consumables, machine, and user information.

⑤ FORCEJET™ Link Icon

This icon indicates whether all parts required for printing are working correctly. The display will differ depending on the consumable or configured details.

- You are using RISO ink.
- You are using non-RISO ink.

When lit: Ink information is entered.

When flashing: Ink information is not entered.

For more information on setting ink information, see the "Troubleshooting Guide".

⑥ Remaining Amount of Ink

These icons indicate the amount of remaining ink for each color. The indicator starts flashing when the time to replace an ink cartridge comes close. Prepare a new ink cartridge for the color that flashes.



- If you are not using RISO ink, the remaining amount of ink is not displayed.

⑦ [Fiery] Button

This button is displayed when using the print controller ComColorExpress FS2100C. Touch this button to show the Fiery mode screen.

For more information, see the user's guide for the print controller.

⑧ Date/Time

The current date and time is displayed.

[Admin Menu] Screen

This screen is only displayed when you are logged in as an administrator. You can access the settings that an administrator can use and modify. For more information, see the "Administrator's Guide".

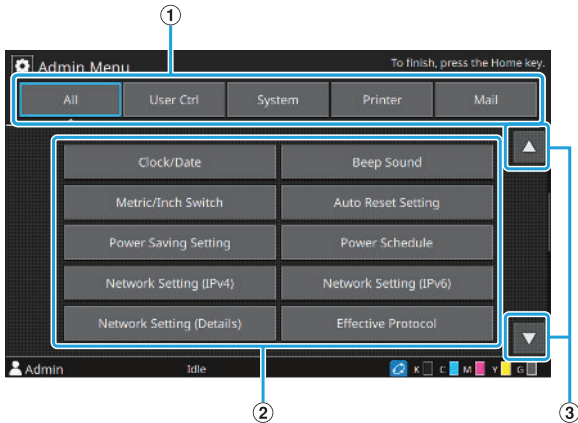

① Category Selection Buttons

The categories of administrator menu setting buttons are displayed here. Touch [All] to show all setting buttons in the administrator menu.



- The [Mail] function may not be displayed. To use this function, contact our dealer or authorized service representative.

② Setting Buttons

Use these buttons to set up the administrator menu functions.

③ Buttons

Use these buttons to scroll through the list.

[Maintenance] Screen

[Print Head Cleaning], [Front Cover Release] and other functions are available on this screen. For more information, see "Maintenance" (p.53) in the "Appendix".

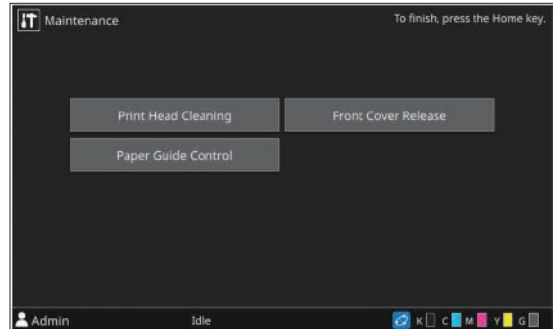

[System Info] Screen

Consumables Screen

This screen displays the status of consumables, such as paper and ink.

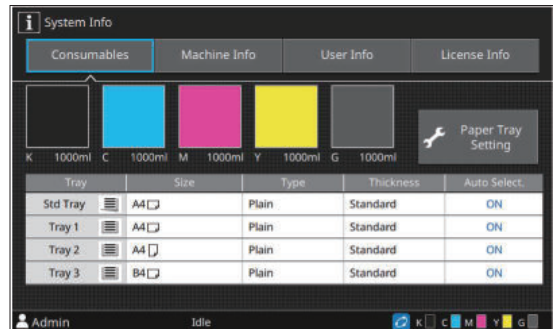

You can touch [Paper Tray Setting] to change the paper tray settings. When changing the paper loaded in a tray, be sure to change the paper tray settings.

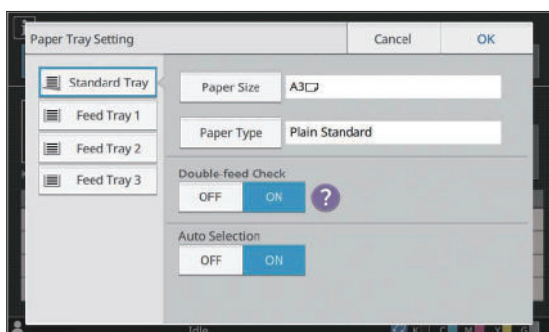

Paper tray selection

Select the paper tray for which you are going to change the settings.

[Paper Size]

Select the paper size.

[Paper Type]

Select the paper type and thickness.

[Double-feed Check]

Select whether to check for the feeding of multiple sheets of paper. Normally, this setting is set to [ON]. This function uses light permeability to detect multiple sheets of paper, so when using paper printed on the back or paper with a dark base color or envelopes, select [OFF].

[Auto Selection]

Set this option to [ON] to make a paper tray available for automatic selection.

■ Changing the Paper Tray Setting

1 Touch [Paper Tray Setting] on the [Consumables] screen.

The [Paper Tray Setting] screen is displayed.

2 Select the paper tray for which you are going to change the settings.

3 Touch [Paper Size].

The [Paper Size] screen is displayed.

4 Select a paper size and touch [OK].

5 Touch [Paper Type].

The [Paper Type] screen is displayed.

6 Select a paper type and touch [OK].

7 Configure [Double-feed Check].

8 Configure [Auto Selection].

9 Touch [OK].



- It is recommended that trays that are loaded with special paper (high-quality paper, color paper, thick paper, paper with letterhead, etc.) should not be set to be available for auto selection.

■ Paper Size

[Auto]

Select this option if you want standard size originals to be detected automatically.

[Standard]

Specify the standard size.

[Custom]

Select this option to select from non-standard paper sizes registered by the administrator in advance.

[Manual]

Specify a non-standard paper size that is not registered.

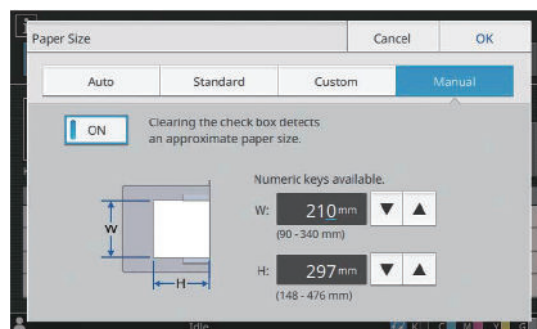

- When [ON] is not selected, the sheet width is set to the width of each paper tray guide. The maximum length of the relevant tray is used for the length.

■ Paper Type

[Type], [Thickness]

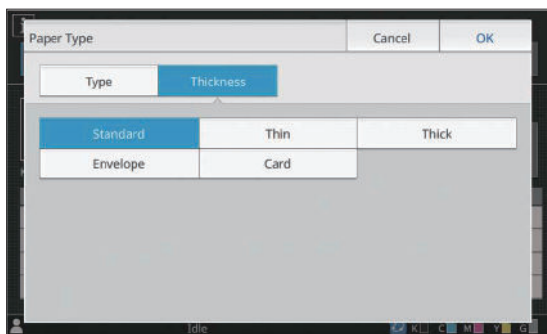
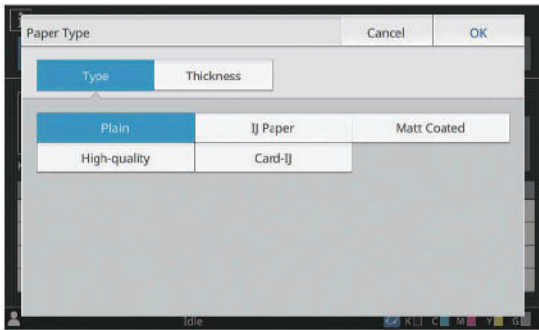

- If the thickness of the paper loaded in the standard tray is set to [Envelope], duplex printing cannot be performed from the standard tray.
- When the paper with different thickness is reloaded in the standard tray, you need to confirm the settings of the paper feed pressure adjustment lever or side air adjustment levers. For more information, see the following:
 - When using the high capacity feeder (p.35 "Loading the Paper in the Standard Tray")
 - When using the double tray feeder (p.45 "Loading the Paper in the Standard Tray")
- When either of the following operations is performed with the high capacity feeder, [Thickness] is automatically changed to [Envelope]:
 - Selecting an envelope size in [Standard] of [Paper Size]
 - Loading envelopes whose size can be detected in the standard tray when [Auto] is selected for [Paper Size]

After that, when either of the following operations is performed, [Thickness] returns to the original setting:

 - Selecting a paper size other than envelopes in [Standard] of [Paper Size]

- Loading paper other than envelopes whose size can be detected in the standard tray when [Auto] is selected for [Paper Size]
- The machine selects the color profile according to the selected paper type. If the printing result is not what you expected, change the paper type.
- When using special paper, you can add settings to [U1] through [U5] for [Thickness]. For more information, contact your dealer or authorized service representative.

Machine Info Screen

This screen displays information about this machine.

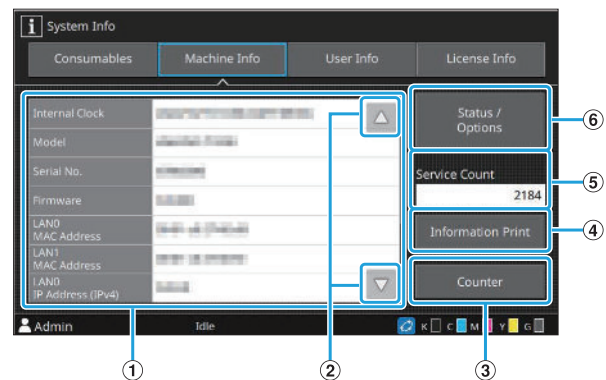

① Machine Info List

You can check the machine information such as the IP address and the firmware version.

② [Up/Down] Buttons

Use these buttons to scroll through the list.

③ [Counter] Button

The detailed count for each paper size is displayed.

④ [Information Print] Button

Touch this button to print the system information or a sample image.

⑤ [Service Count] Button

The total number of times of paper transport when printing is displayed.

The number of times of paper transport is counted as 2 times per sheet when duplex printing is performed.

⑥ [Status / Options] Button

Touch this button to display information on the connected equipment and its status.

User Info Screen

This screen displays the user name and groups of the user logged in.

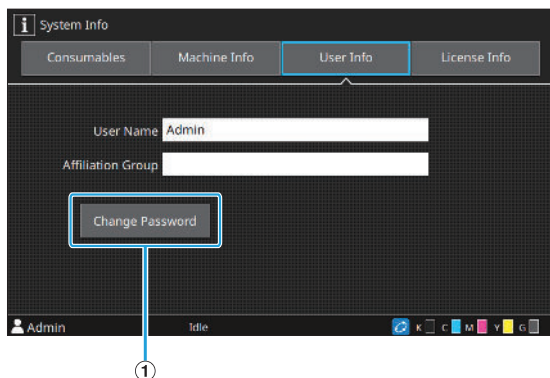

- ① [Change Password] Button
Touch this button to change the password.

License Info Screen

This screen displays the license information of the system used with this product.

Touch Panel

You can operate the machine by using the touch panel and keys on the operation panel. You can touch buttons displayed on the screen to select items, switch between screens by flicking your finger on the touch panel, or scroll through lists by swiping your finger.

Scrolling

You can also scroll through scrollable screens and lists with the drag operation by sliding your finger to the left/right or top/bottom without lifting your finger from the touch panel. Remove your finger from the touch panel to stop the scrolling.

Selecting a Button

To select a button on the touch panel, touch the button with your finger. Either a part of or the entire selected button will turn blue.

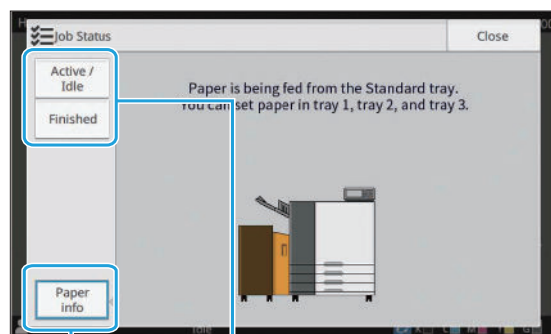
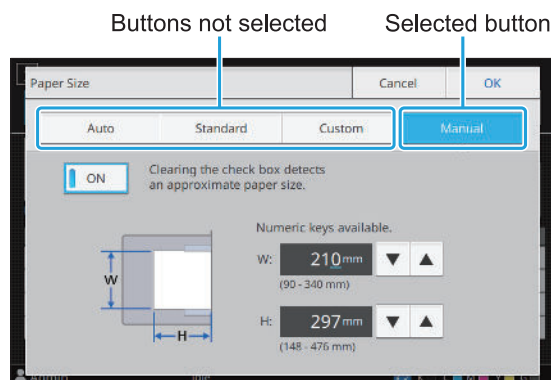

Selected button Buttons not selected

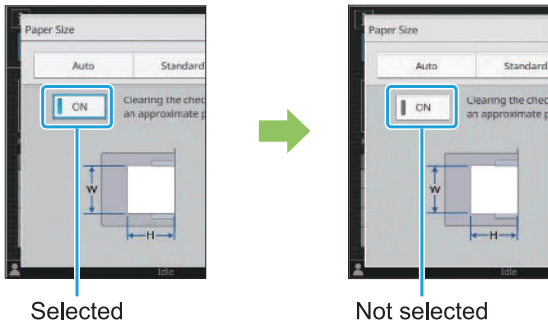

Buttons that are not available under the current conditions are grayed out. You can use these buttons when the required conditions are met.

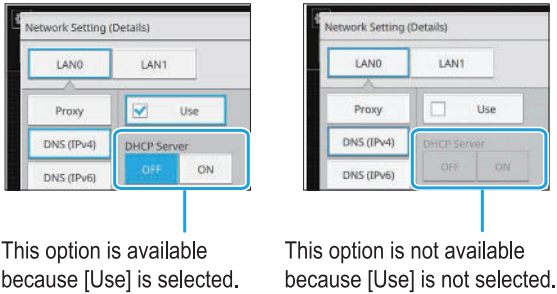

Confirming / Canceling a Setting

When [OK] is displayed on a screen, you must touch [OK] to save the settings. If you do not touch [OK], the settings may be canceled. To cancel the settings you have edited, touch [Cancel].

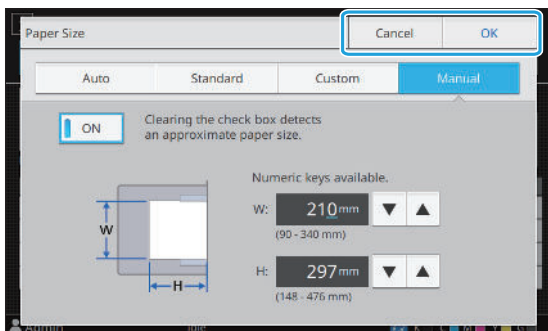

Entering Text

When entering user names or passwords, enter the required information on the text input screen.

1 Touch the characters you want to enter one by one.

To move the cursor, touch [←] or [→]. Touch [✕] if you need to erase a character to the left of the cursor.



- If the available characters are restricted, as is the case with passwords, the characters that cannot be used are grayed out.
- To enter an uppercase letter, touch [Shift] first, and enter the character. To return to the lowercase letter input, touch [Shift] again.
- The maximum number of characters that can be entered and the current number of characters entered are displayed to the right of the text input field.



2 After entering the text, touch [OK].



- Depending on the entry area, touching the area may not open up an entry screen. In such cases, use the numeric keys.
- The current selected area is indicated by a flashing short line under numbers or letters. To switch the area, touch the area that you want to enter text in.

Preparation

This chapter explains how to turn on the power, load the paper, and do other preparations to make this machine ready for use.



- When using the feed tray, you do not need to set the standard tray.

Power

The machine has two power switches, the main power switch and the [Power] key. Use the main power switch to turn on the main power to the whole machine.

Press the [Power] key to start this machine.



- To turn off the power to this machine in normal use, press and hold the [Power] key on the operation panel.
- Do not turn off the main power except when the machine is not going to be used for an extended period of time or when the power supply is unintentionally stopped due to lightning strike or other unexpected causes.

Turning On the Power

- 1 Make sure that the power plug is inserted into an electrical outlet.**
- 2 Turn on the main power switch.**
The [Main Power] LED on the operation panel turns on.
- 3 Press the [Power] key on the operation panel.**
The power turns on and the [Power] key lights up.

Turning Off the Power

- 1 Press and hold the [Power] key on the operation panel.**
- 2 Check that the [Power] key is off, then turn off the main power switch.**
The [Main Power] LED turns off.



- To turn on the main power again, first make sure that the [Main Power] LED is off.
- Remove the power plug only after turning off the main power switch.

Power-saving Features

If you leave the machine unattended for some time, it automatically goes to power saving mode. The power saving mode has two states, the backlight off state and the sleep state. The respective transition times and power consumption in sleep are set by the administrator. When the power saving mode turns on, the touch panel turns off, and the [Wake Up] key turns on. When you press the [Wake Up] key, the power saving mode is canceled, and the machine returns to normal operating mode. The machine takes longer to recover from the sleep state than from the backlight off state.

Loading the Paper

Load the paper in the feed trays and the standard tray.



- We recommend loading the feed trays with types of paper you will use most often.
- Use the standard tray for the following types of paper:
 - Thick paper and other special paper
 - Preprinted paper
 - Postcards
 - Envelopes

For more information, see "Printing Paper" (p.12).

- For information on how to load paper in the standard tray, see "Loading the Paper in the Standard Tray" (p.35).

Loading the Paper in the Feed Trays

- 1 Pull a tray out, toward the front.

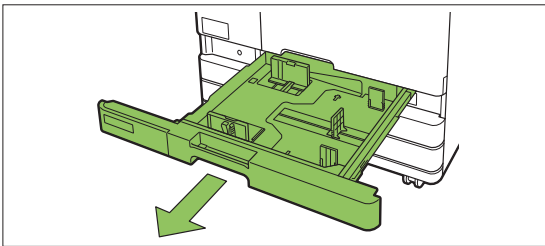

- 2 Hold the lever of the paper feed guide, and pull it forward to spread the paper feed guide until it stops.

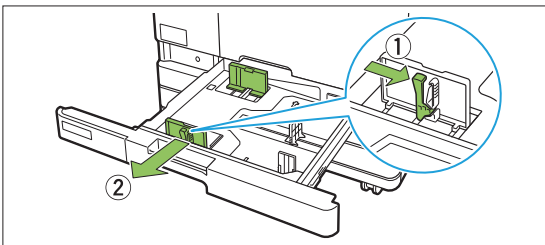

- 3 Move the stopper to make space.
Move the stopper by holding both sides.

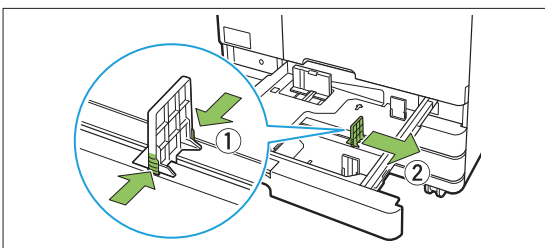

- 4 Load the paper.
When using paper with different characteristics on the front and back sides, load the printing side face down. Do not load too many sheets.

When loading the paper, be careful not to let its edge contact the paper guides to prevent it from being bent.

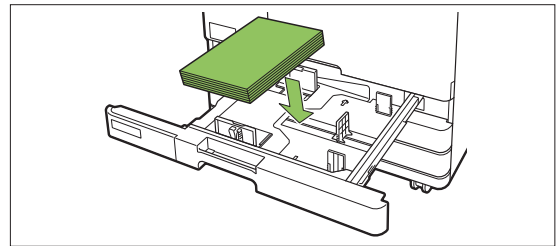

- 5 Move the paper feed guide and stopper against the edge of the paper.

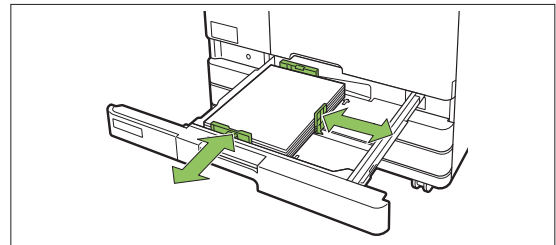

- The machine detects the size of the paper based on the stopper position. Be sure to move the guides against the edge of the paper.
- To set A3 paper or B4 paper, install the A3/B4 paper guide properly for each type. Pinch both sides of the A3/B4 paper guide, slide it out and then slide it into the appropriate hole for the desired paper size.

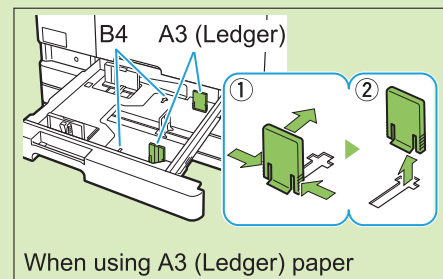

- 6 Push the tray back into the machine.

7 On the operation panel, check the tray settings.

When you have switched to a different type or size of paper, update the feed tray settings. (p.21 "Changing the Paper Tray Setting")

System Configuration

The print controller is required for printing with the machine.

The print controller converts print data used in print workflow such as PS (PostScript) to RISORINC/C IV data and controls the print job.

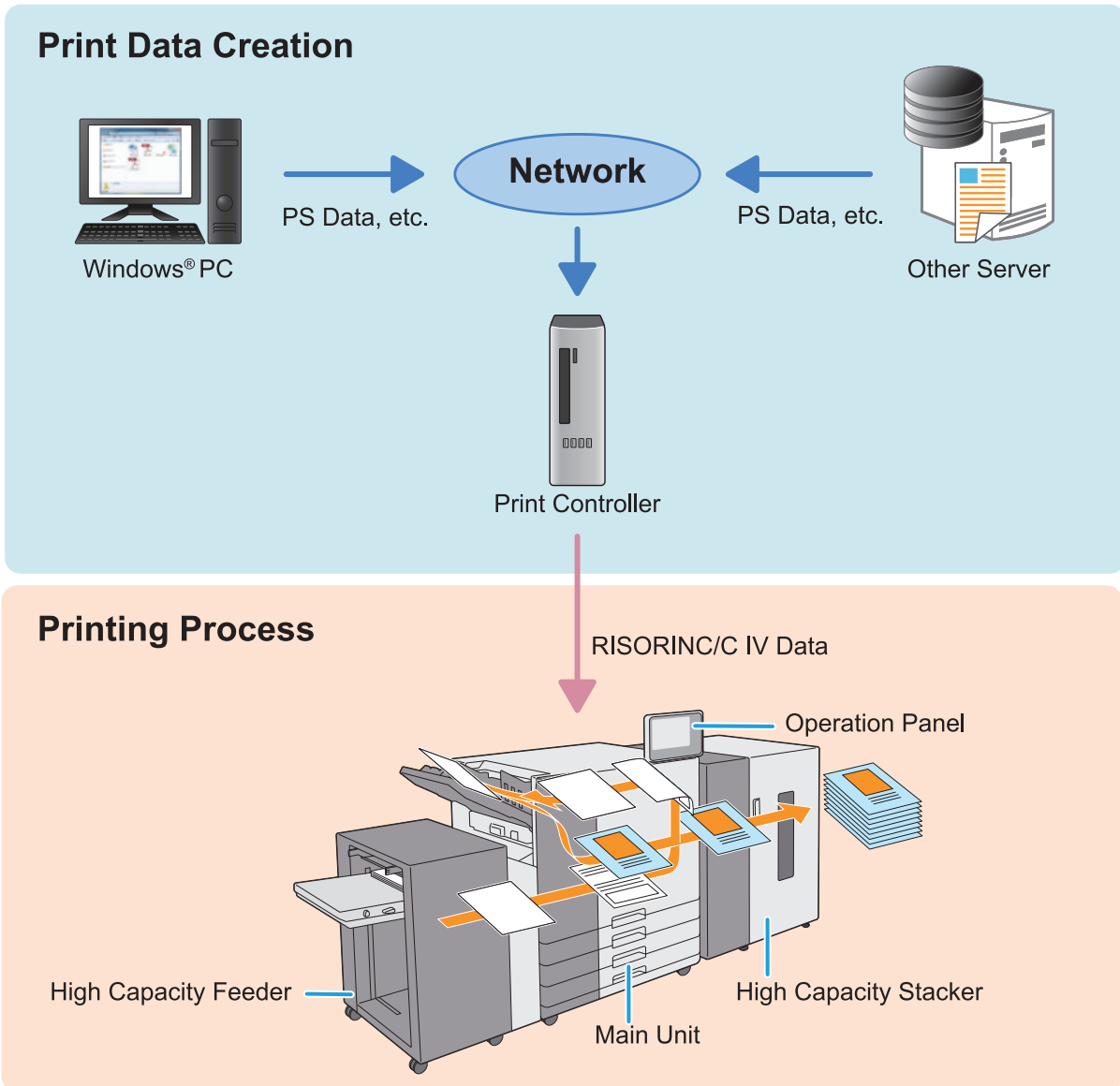

- The power consumption of the machine may get high. Make sure to take power supply from multiple places instead of from one place.
- The maximum allowable voltage for all input/output connection is 5V.



- Use a commercially available ethernet shielded cable. You can use both straight and crossover cables to connect the machine to computers.

It is recommended that you use one of the following types of ethernet shielded cables according to your network environment.

- Cat 5 (Cat 5e) cable for 100BASE network
- Cat 5e cable for 1000BASE network

- Connect the print controller to the LAN1 terminal on the rear of the machine.
 - You cannot directly connect the machine to a communication line offered by a telecommunication carrier (mobile communications company, fixed-line telecoms company, Internet provider, etc.) When connecting the machine to the network, make sure that the connection is made via a router etc.
 - Print controller corresponds to AFP / IPDS* print workflow which is often used for transaction printing.
 - * Supported only on αStream "Pro"
 - For the printing method and settings of print controller, see the user's guide for the print controller.
 - You cannot change the paper size during a print job. When using different size of paper, take out the printed papers from the stacking tray.
-

About Jobs

You can press the [Job Status] key to check jobs that are in progress or finished.



- A job is the unit of tasks performed by this machine.

[Active / Idle] Screen

Touching [Active / Idle] displays a list of jobs in progress and jobs waiting to be printed. Jobs are printed in order from the top of the list.

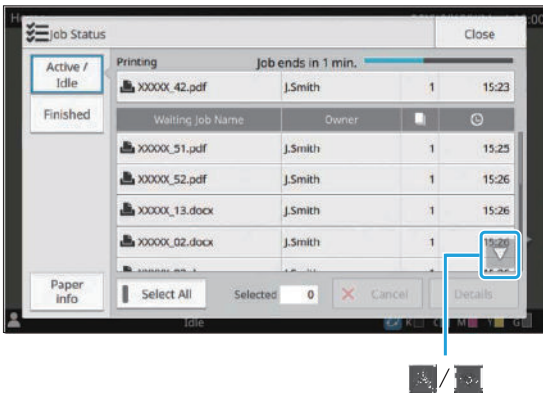

Job List

The job list displays the job name, status, owner name, number of copies (📄), and receiving time (🕒) for jobs that are being printed, in processing, and waiting to be printed. An icon indicating the job type is displayed on the left side of the job name.

Icon	Job Type
	Print job
	Broken job



- / can be touched to scroll through the list.
- Touch [Select All] to select all jobs in the list.

Checking the Current Status of a Job

The current status of the job being printed and processed is displayed with a progress bar. The expected finish time is also displayed for the jobs currently printed.



- When the number of pages of the print job is unknown, the expected finish time will not be displayed.

Canceling a Job

To cancel a job, select the job that you want to cancel and either touch [Cancel] or press the [Stop] key.

Checking the Details of a Job

Touch [Details] to view the details of a job in progress or waiting to be printed.

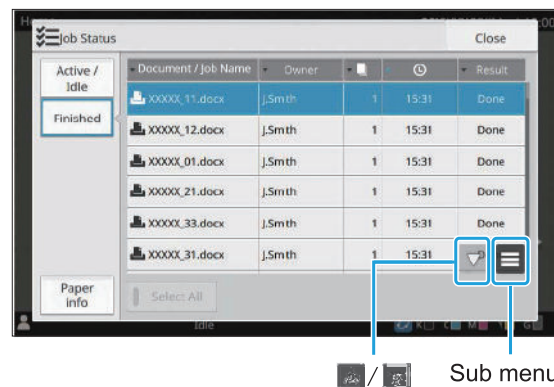

[Finished] Screen

Touch [Finished] to display a list of completed jobs.





You can check the document/job name, owner name, number of printed copies (📄), print date/time (🕒), and processing result.

An icon indicating the job type is displayed on the left side of the job name.

Icon	Job Type
	Print job
	Broken job



- Touch the sub menu to check the details of a job, print the job again, or delete the job.
-  /  can be touched to scroll through the list.
- Touch categories such as [Document / Job Name] or [Owner] to switch the sorting order between ascending and descending for display.
- Touch [Select All] to select all jobs in the list.
- This list also displays a history of processed jobs. The job type, save period, and number of jobs displayed in the list are specified by the administrator. Contact your administrator for details.

[Paper info] Screen

Touch [Paper info] to display the tray which is feeding paper.

When you want to add paper during printing with the machine, check the available tray on this screen.

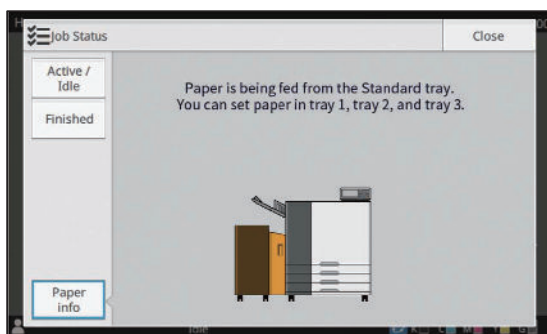

Printing

Sending Print Data

The print data sent to the print controller is printed with the machine using "αStream".



- "αStream" is an output application that processes print data. It is always running when the power of the print controller is on.
- For the printing method and settings of print controller, see the user's guide for the print controller.

1 Select data to print via "αStream".

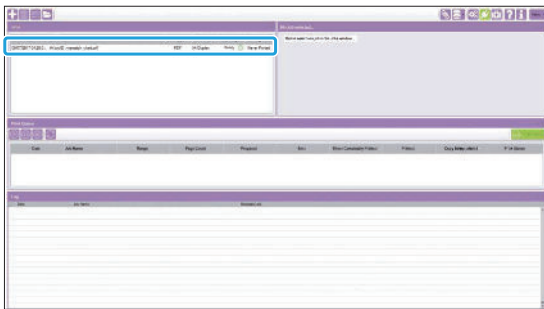

2 Check the print settings via "αStream".

3 Check the paper settings on the operation panel.

You can check the paper settings on the [System Info] - [Consumables] screen.

Also, make sure correct paper is inserted in the specified feed tray, and the remaining amount of ink is sufficient.

4 On the print controller, Click [Start].

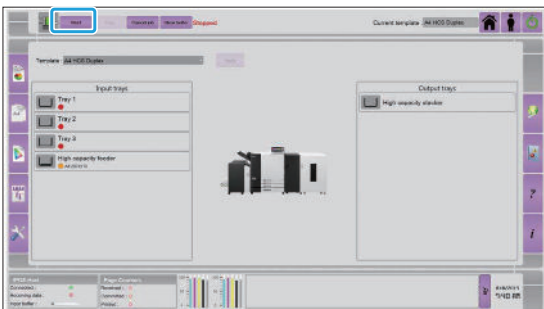

Print data will be sent to the machine, and the printing starts automatically.



- When printing stops by an error, click [Start] again on the print controller after resolving the problem following the instructions in the displayed message.

Changing the Settings

1 Select data to print via "αStream".

2 Change the print settings via "αStream".

3 Change the paper settings on the operation panel.

You can change the paper settings from [Paper Tray Setting] on the [System Info] - [Consumables] screen.

Also, make sure correct paper is inserted in the specified feed tray.

Dedicated Equipment

High Capacity Feeder

The high capacity feeder allows you to load the unit with approximately 4,000 sheets of printing paper (when using plain paper, recycled paper).

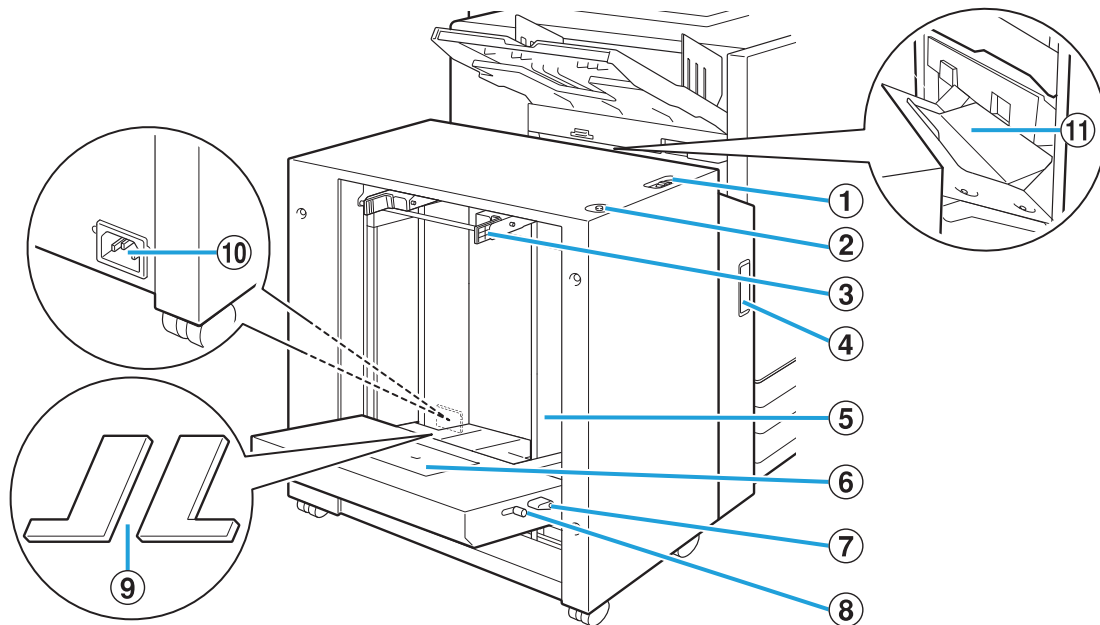

① Paper Feed Pressure Adjustment Lever

Use this lever to adjust the paper feed pressure for either "NORMAL" or "CARD" to suit the paper type loaded in the high capacity feeder.

② Standard Tray Descent Button

Use this button to move the high capacity feeder up or down when replacing or adding the paper to it.

③ Paper Feed Guide Levers

Pinch these levers to slide the paper feed guide. Release the levers to fix the paper feed guide in position. Levers are located on both sides of the standard tray paper guide, in two places.

④ Front Cover

Open this cover when there is a paper jam.

⑤ Standard Tray Paper Guide

This guide prevents paper in the high capacity feeder from becoming misaligned.

⑥ Envelope Guide

Use this guide when printing on an envelope. Depending on the type of envelope being used, it is necessary to adjust the angle of inclination.

⑦ Envelope Guide Angle Adjustment Lever

Use this lever to adjust the angle of inclination of the envelope guide. The angle of the envelope guide can be adjusted to four levels.

⑧ Envelope Guide Paper Feed Pressure Adjustment Lever

Use this lever to adjust the paper feed pressure to suit the paper quality of the envelope being used.

⑨ Standard Tray Padding Covers

Remove the covers when you load sheets smaller than A4 (Letter) or larger than A3 (Ledger), or C5/DL-LEF envelopes.

⑩ High Capacity Feeder Socket

Connect the high capacity feeder power cord. The socket is located on the rear of the side of the standard tray.

⑪ Transfer Cover

If a paper jam occurs, open this cover and remove the jammed sheet.

Loading the Paper in the Standard Tray

1 Spread the paper feed guides.

Pinch the paper feed guide levers (both sides) to unlock and slide the guides.

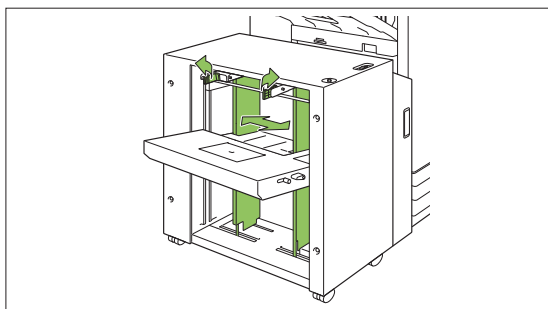

2 Load the paper.

Load the paper with the printing side face up.

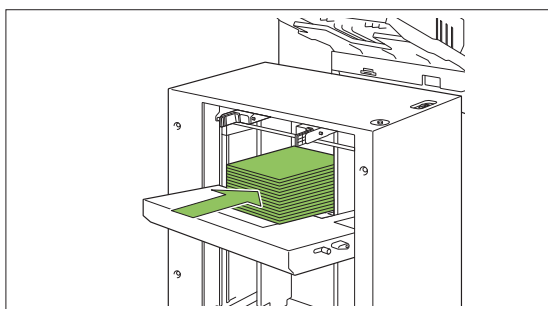

- When a large amount of paper is loaded at once, it is difficult to properly adjust the guides and may prevent the paper from being loaded correctly. (The paper may bend, warp, or be misaligned.) Divide the paper into several bulks when loading the paper. When setting a large amount of paper at once, see "When Setting a Large Amount of Paper at Once" (p.36).

When loading envelopes

Be sure to load envelopes with their flaps open and their bottom side entering the machine first.

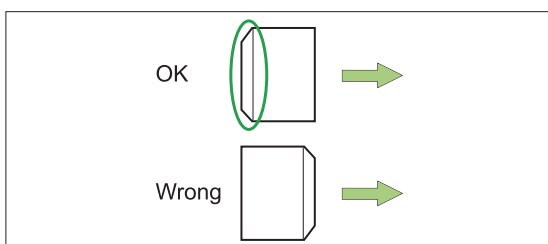

The adjustment of the angle of inclination of the envelope guide is configured using the envelope guide angle adjustment lever.

Note that it is also necessary to adjust the paper feed pressure depending on the paper quality of the envelopes being used. Configure the pressure with the envelope guide paper pressure adjustment lever. Slide the lever while lifting it up. See the sticker near the lever to set a pressure that is appropriate for the envelopes being used.

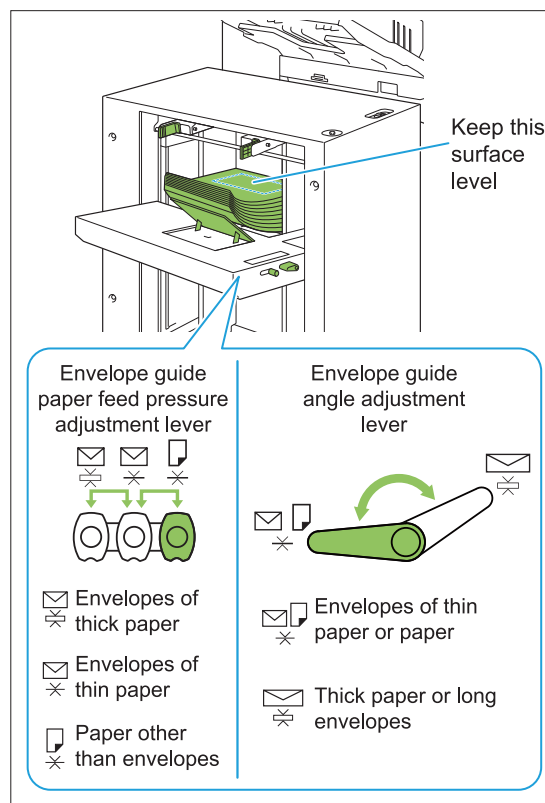

3 Adjust the paper feed guides so that they are suitable for the paper size.

Slide the guides while pinching the paper feed guide levers to match the guides against the edges of the paper, and release the paper feed guide levers to fix the guides in position.

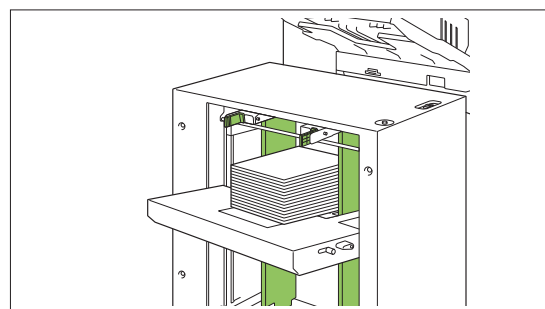

4 Adjust the paper feed pressure adjustment lever.

For general use, set to "NORMAL". For thick paper or other paper for special purposes, set to "CARD".

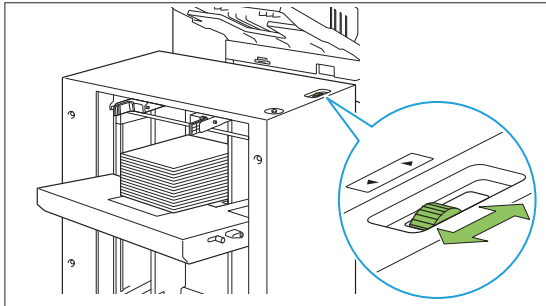

5 On the operation panel, check the tray settings.

Configure the paper size and type with [Paper Tray Setting]. (p.21 "Changing the Paper Tray Setting")
When changing the paper loaded in a tray, be sure to change the settings in [Paper Tray Setting].

■ Regarding the Standard Tray Padding Covers

Depending on the size of the paper being used, the standard tray padding covers may or may not be necessary.

Cases When the Standard Tray Padding Covers Are Necessary

Properly attach and use the standard tray padding covers when the paper size is B5-LEF, A4-LEF, B4, A3, or a custom size having a width of 257 mm (10 1/8") or more.

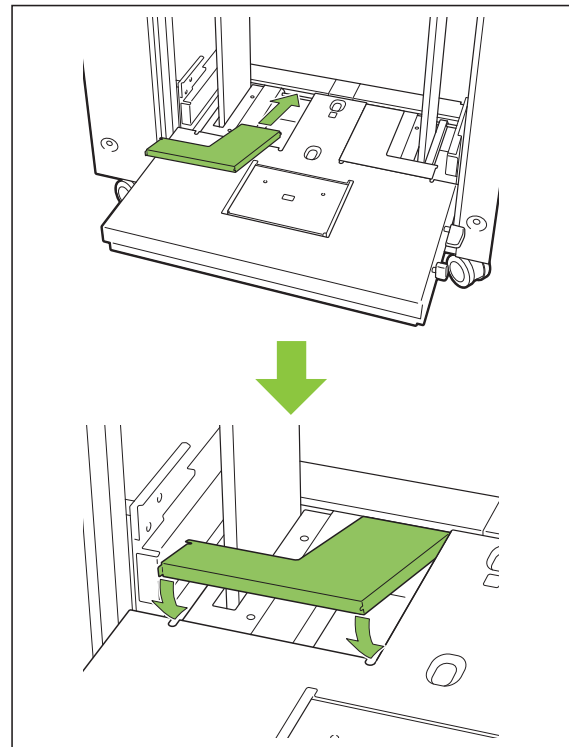

Cases When the Standard Tray Padding Covers Are Not Necessary

When the size of the paper is less than A4 vertically or more than A3, or when using envelopes of the C5 or DL-LEF size, remove the standard tray padding cover. The paper feed guide cannot be moved while the cover is in place.

■ When Setting a Large Amount of Paper at Once

- 1 Spread the paper feed guides and load approximately 500 sheets onto the standard tray.**
- 2 Adjust the paper feed guides so that they are suitable for the paper size.**
Move the guides against the edges of the paper, and release the lever to lock.
- 3 Load the rest of the paper.**
Procedures after all of the paper has been loaded are the same as when loading the paper for normal operation. Perform step 4 and 5 described in "Loading the Paper in the Standard Tray" (p.35).

Adding the Paper

Use the standard tray descent button when adding the paper. The position to which the standard tray is lowered will differ depending on how the standard tray descent button is operated. Note that the standard tray is automatically lowered when all paper is removed.

1 Press the standard tray descent button to lower the standard tray.

Hold down the standard tray descent button.

The standard tray will keep lowering for as long as the button is being pressed. Hold the button down until the tray reaches the desired position.

Press and quickly release the standard tray descent button.

The standard tray will be lowered to a certain position.

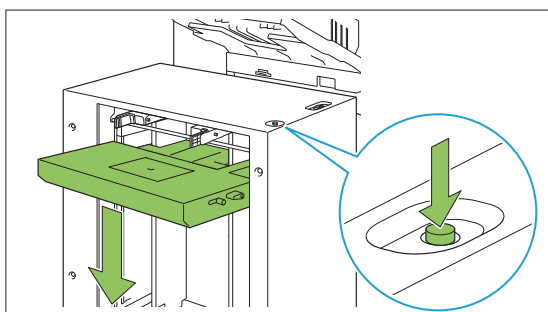

- The position to which the standard tray is lowered when the standard tray descent button is pressed or when paper runs out is set by the administrator. Contact your administrator for details.
- When the standard tray is lowered to the lowermost position, it is possible to load a large amount of paper at once but this will require that you squat when loading the paper. To load the paper while standing or when it is rare that you need to load a large amount of paper at once, avoid lowering the standard tray to the lowermost position.
- The position to which the standard tray is lowered can be conveniently configured to suit scenes of use. To change the position to which the standard tray is lowered, contact your administrator.

2 Add the Paper.

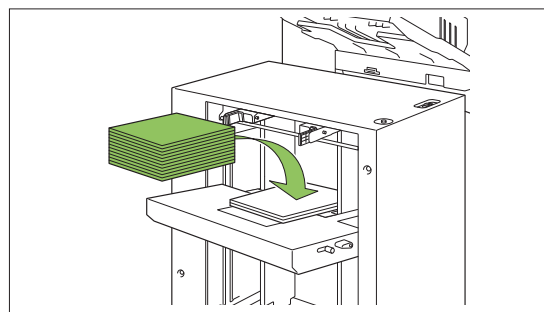

■ When Adding a Large Amount of Paper

It is possible to set a greater amount of paper at once by holding down the standard tray descent button and lowering the standard tray to its lowermost position.



- The position to which the standard tray is lowered when the standard tray descent button is pressed shortly or when paper runs out is set by the administrator. To change the position to which the standard tray is lowered, contact your administrator.

High Capacity Stacker

The high capacity stacker allows you to output approximately 4,000 sheets of printing paper (when using plain paper, recycled paper).

The printouts that have been output can be removed at once with the dedicated carriage.

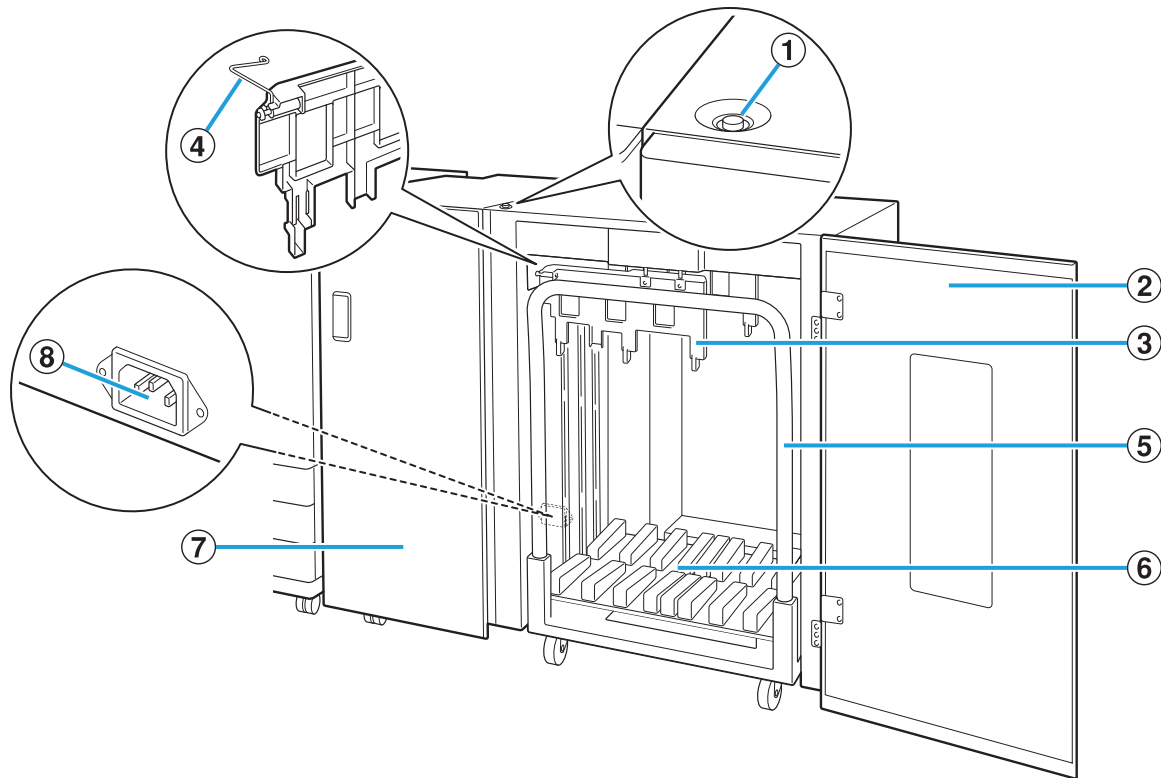

① Stacking Tray Descent Button

Press this button to remove printouts from the stacking tray. If you press the stacking tray descent button, the stacking tray lowers to the bottom (the position of the carriage). The stacking tray stops when you press the stacking tray descent button during lowering. If you press the button again, the stacking tray continues lowering. The stacking tray does not operate during printing even if you press the stacking tray descent button. Press with the right and left covers closed.

② Right Cover

Open this cover when removing printouts, setting the carriage in position, or when removing paper jams.

③ Paper Guide

Use this guide to prevent printouts that have been output from becoming misaligned.

④ Corrugators

Set the corrugators to feed paper smoothly according to the paper type and align printouts to stack neatly.

⑤ Carriage

Set this dedicated carriage inside the high capacity stacker. Connect the stacking tray to the carriage to transport high-volume printouts.

⑥ Stacking Tray

Printouts are output to this tray.

⑦ Left Cover

If a paper jam occurs while paper is being transported, open this cover and remove the jammed paper.

⑧ High Capacity Stacker Socket

Connect the high capacity stacker power cord. The socket is located toward the bottom on the rear of the left cover.



- Do not open the cover during printing. You cannot print with the cover open.
- Be sure to use the dedicated carriage with the high capacity stacker.

Setting the Corrugators

As the state of paper transport and alignment will differ depending on the size or type of paper being used, adjust the corrugators so that the output and paper of printouts will be aligned.



- Normally, it will not be necessary to adjust the corrugators for printing. Adjust the corrugators for better feeding and printout alignment.
- Paper alignment may not improve according to the paper size, paper type, environment and storage. For more information, contact your dealer or authorized service representative.

Raising the Corrugators

Normally, the unit is used with the corrugators raised.

- 1 Lift the front corrugator while pressing it toward the machine (to the left).

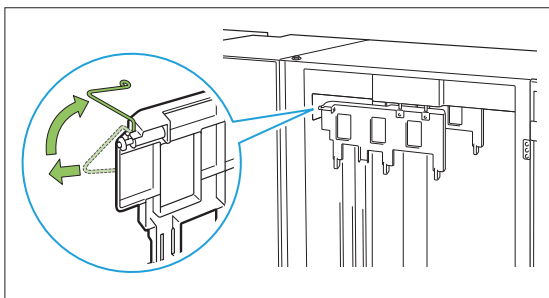

- 2 Similarly lift the back corrugator while pressing it toward the machine (to the left).

Lowering the Corrugators

The unit is used with the corrugators lowered when printing on A3/B4/B5-LEF paper or thin paper.

- 1 Lower the front corrugator while pressing it toward the machine (to the left).

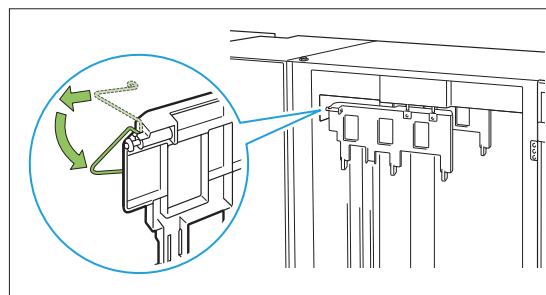

- 2 Similarly lower the back corrugator while pressing it toward the machine (to the left).

Removing Printouts

Remove printouts from the high capacity stacker. There are two ways of removing the printouts.



- The printouts are to be removed when the stacking tray is at a full stop. A message indicating the status of the stacking tray is displayed on the operation panel. Follow the message.

- **When removing printouts with the carriage**
Remove printouts using the dedicated carriage for the high capacity stacker.
- **When removing only the printouts**
Printouts can be removed without pulling out the dedicated carriage. You can remove printouts without waiting for the stacking tray to lower to the bottom.

■ When Removing Printouts With the Carriage

1 Press the stacking tray descent button.

The stacking tray will be automatically lowered to its lowermost position after approximately 3,200 to 4,000 (full) sheets have been output.

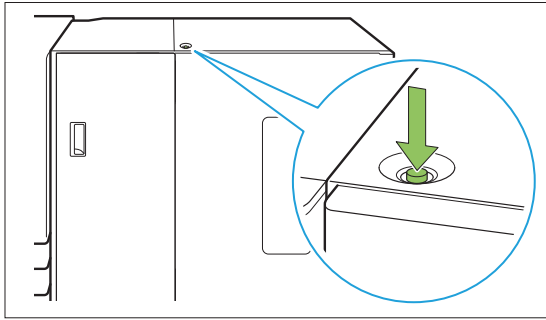

- Press the stacking tray descent button in a state where the covers on both sides of the high capacity stacker are closed. The stacking tray will not operate if the covers are open.
- Once printing has ended, the stacking tray will be automatically lowered to a position configured by the administrator. To change the position to which the stacking tray is lowered, contact your administrator.
- If you accidentally press the stacking tray descent button while printing, be sure to remove the printouts. In a state where printouts exist on the tray, the unit will not be capable of raising the stacking tray to the position for output.

2 Open the right cover of the high capacity stacker.

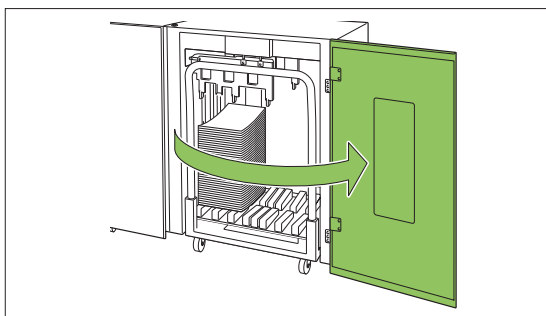

3 Pull out the carriage along with the stacking tray on it.

- Slowly pull out the carriage while holding its handle. Abruptly moving the cart may cause the printouts to collapse.

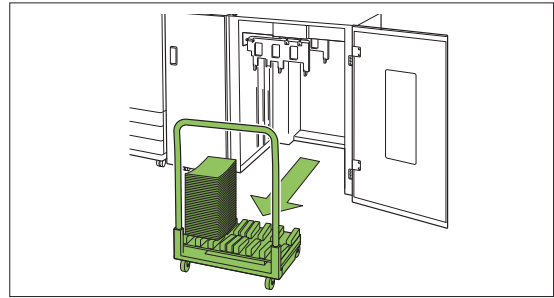

4 Remove printouts from the carriage.

5 Return the carriage to the high capacity stacker.

- Be sure to return the carriage in a state where the stacking tray has been set.

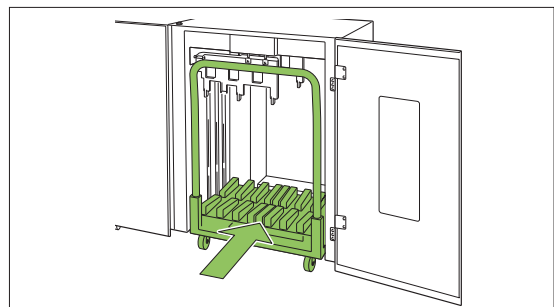

6 Close the right cover of the high capacity stacker.

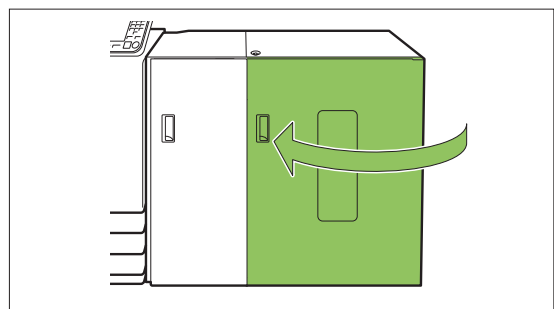

■ When Removing Only the Printouts

1 Open the right cover of the high capacity stacker.

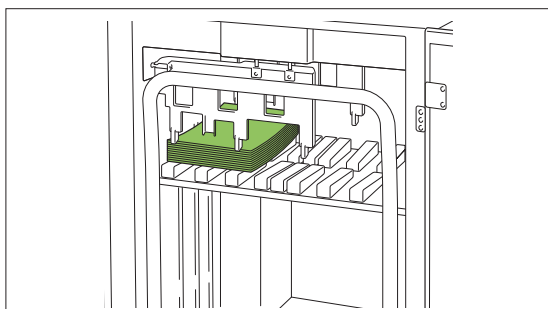

- The position at which the stacking tray will stop is configured by the administrator. To change the position to which the tray is lowered, contact your administrator.
- Depending on the position at which the stacking tray will stop, the printouts may interfere with the guides making it difficult to be removed. In such case, close the right cover, press the stacking tray descent button, and remove the printouts after the stacking tray has been lowered.

2 Remove the printouts.

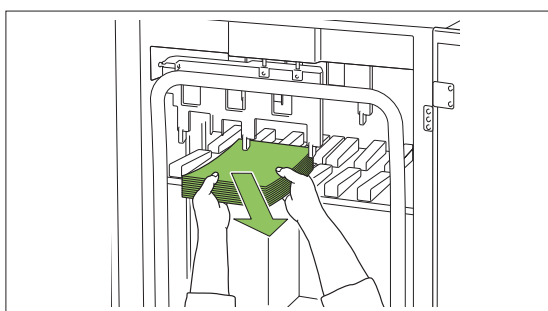

- Depending on the size of the paper that has been output, the printouts may interfere with the handle of the carriage making it difficult to be removed. In such case, close the right cover, press the stacking tray descent button, and lower the stacking tray to the carriage. This will allow you to pull out the entire carriage and remove the paper.

3 Close the right cover of the high capacity stacker.



- If the carriage has been pulled out in step 2, close the right cover after setting the carriage back into the high capacity stacker.
- When configured so that the stacking tray is not lowered even after printing has ended, if there is paper on the stacking tray, the output guide is unable to move and may not be able to support the size of paper for the next job. Before printing jobs of different paper sizes, paper orientations, or paper tray settings, be sure to remove the paper on the stacking tray.

Setting the Stacking Tray on the Carriage

The stacking tray can be removed from the carriage. When you have removed the stacking tray to remove printouts, set the stacking tray on the carriage and return the high capacity stacker together with the carriage.

1 Align the end of the stacking tray with the two screws at the base of the handle on the carriage.

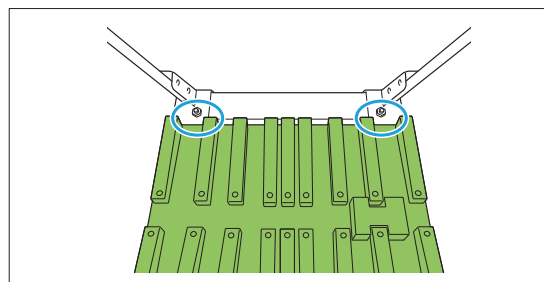

2 Set the carriage by inserting its protrusions into the holes in the stacking tray.

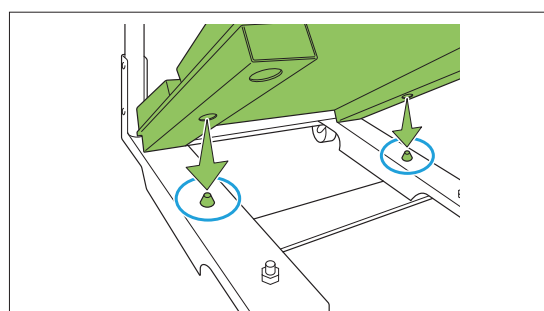

Maintenance Mode Settings

■ Paper Guide Control

Adjust the position of the paper guides. For more information, see "Paper Guide Control" (p.54) in the "Appendix".

Double Tray Feeder

Connecting the double tray feeder allows you to load up to 8,000 sheets* of paper (4,000 sheets* for the upper and lower feed trays, respectively). Equipped with the air feeding system that suppresses the occurrence of paper misfeed and multiple-paper feed, the double tray feeder can feed sheets of paper without delay.

* When using plain paper, recycled paper (85 g/m² (23-lb bond))

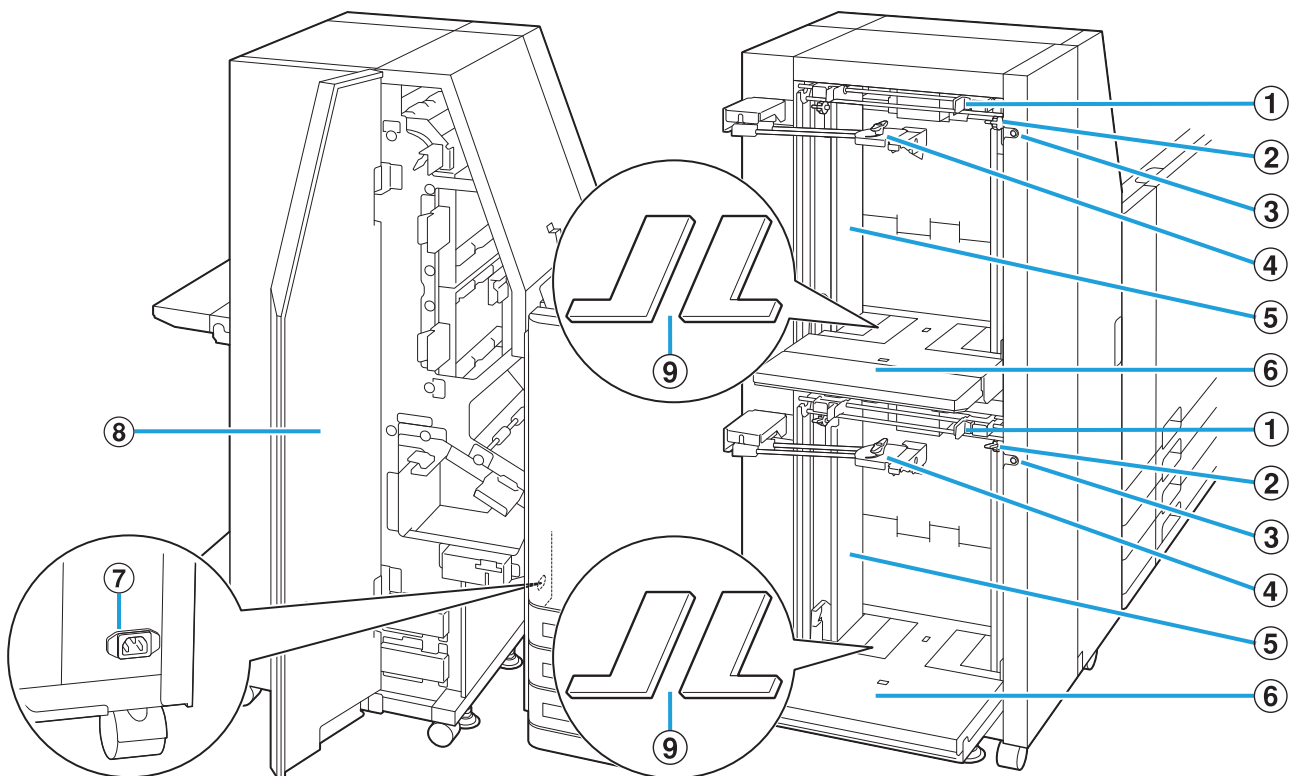

① Paper Feed Guide Levers

Pinch these levers to slide the paper feed guide (side). Release the levers to fix the paper feed guide in position. The levers are located on both sides of the standard tray paper guide (side), in two places.

② Side Air Adjustment Levers

Use these levers to adjust the air ejection amount for either "NORMAL" or "CARD" to suit the paper type loaded in the double tray feeder. The levers are located on both sides of the standard tray paper guide (side), in two places.

③ Standard Tray Descent Button

Use this button to move the double tray feeder up or down when replacing or adding the paper to it.

④ Standard Tray Paper Guide (End)

This guide prevents paper in the double tray feeder from becoming misaligned. Turn the knob at the tip counter-clockwise to unlock the guide. Move the guide to align with the paper stack and turn the knob clockwise to fix the paper guide in position.

⑤ Standard Tray Paper Guide (Side)

This guide prevents paper in the double tray feeder from becoming misaligned.

⑥ Standard Tray

Load paper on this tray.

Upper tray: Feed 1, Lower tray: Feed 2

⑦ Double Tray Feeder Socket

Connect the double tray feeder power cord. The socket is located on the backward side of the double tray feeder.

⑧ Front Cover

If a paper jam occurs, open this cover and remove the jammed sheet.

⑨ Standard Tray Padding Covers

Remove the covers when you load sheets smaller than A4 (Letter).

Caution Label

For safety use, the caution label below is adhered to the double tray feeder. When operating or maintaining the double tray feeder, obey the instructions on the caution label for safe use. Do not remove or dirty the label.

If the label is not stuck on the double tray feeder, is peeling off, or is unreadable, contact your dealer or authorized service representative.

■ Location of the Caution Label

The location of the caution label (warning) is shown below.

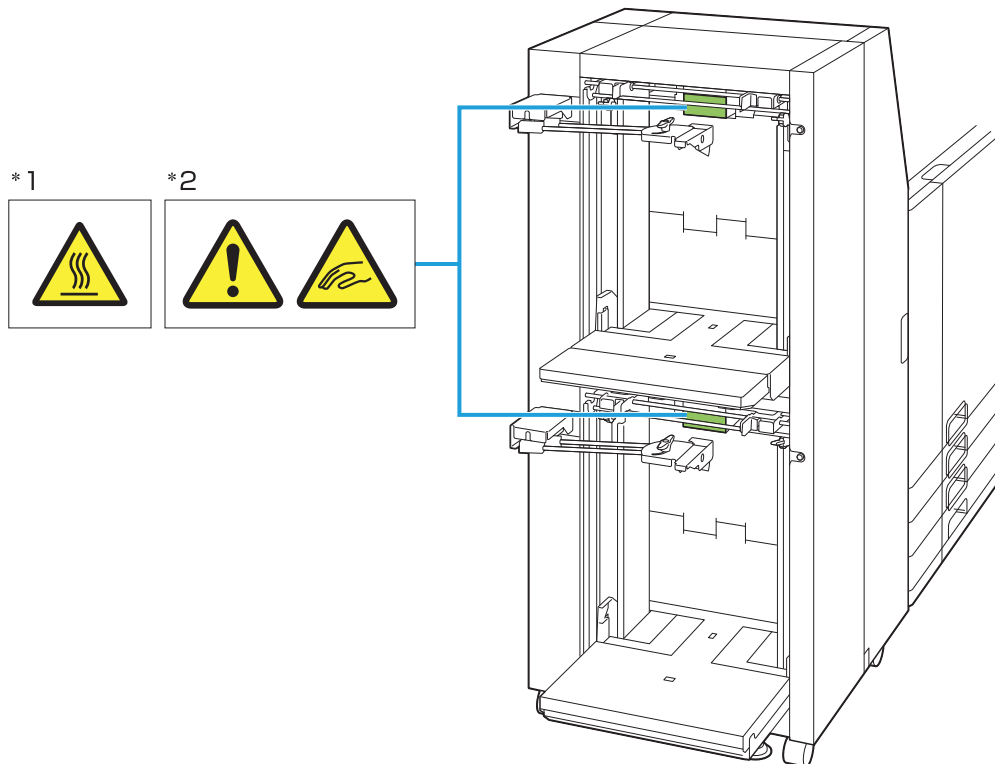

■ Label Details

*1 The location of the label may be high temperature. Contact may result in burn.

*2 Your fingers may become caught while the double tray feeder moves or when you load paper in the standard tray.

Loading the Paper in the Standard Tray

How to load paper is common to the upper and lower standard trays. This section describes how to load paper in the upper standard tray as an example.



- Paper cannot be fed continuously if you load different size paper in the upper and lower standard trays.



- The feed extension plate of the upper standard tray can be detached. Detach the feed extension plate if it gets in the way of loading paper in the lower standard tray.

1 Spread the paper feed guides (side).

Pinch the paper feed guide levers (both sides) to unlock and slide the guides.

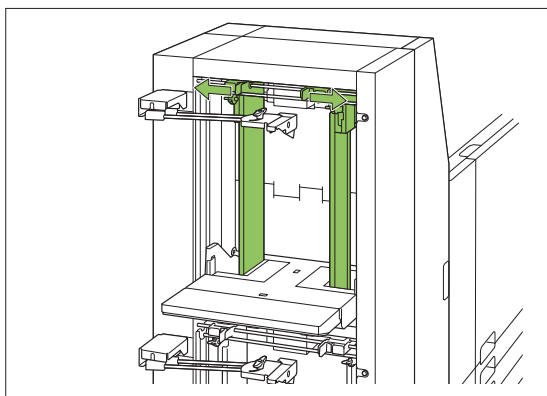

2 Spread the paper feed guide (end).

Turn the knob of the paper feed guide (end) counterclockwise to unlock and spread the guide.

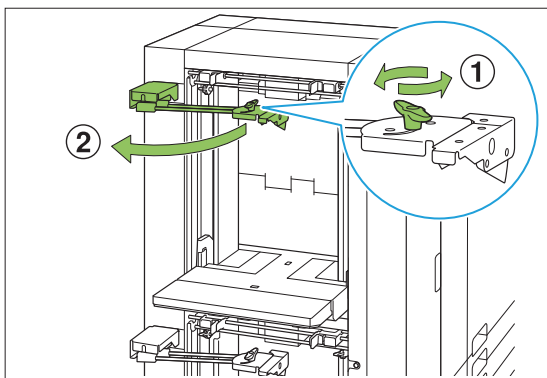

3 Load the paper.

Load about 500 sheets at a time in the standard tray.

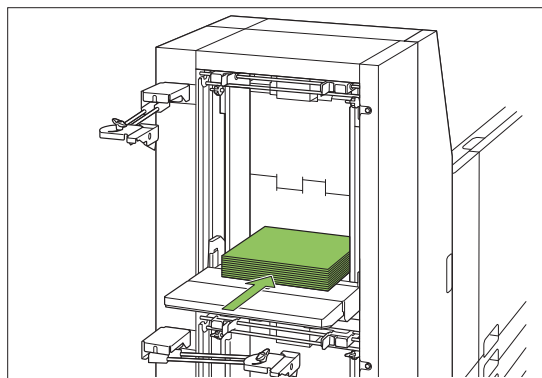

4 Adjust the paper feed guides (side) so that they are suitable for the paper size.

Slide the guides while pinching the paper feed guide levers to match the guides against the edges of the paper.

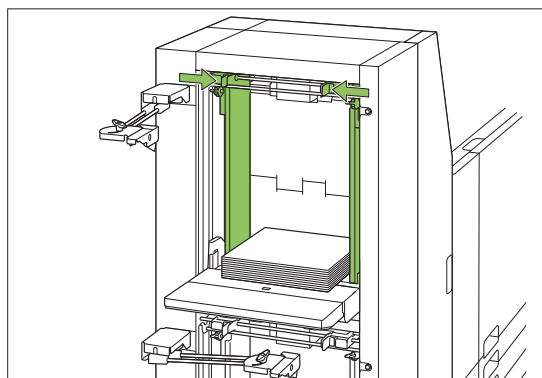

5 Set the remaining paper.

6 Press and quickly release the standard tray descent button twice.

The standard tray moves up to the paper feeding position.

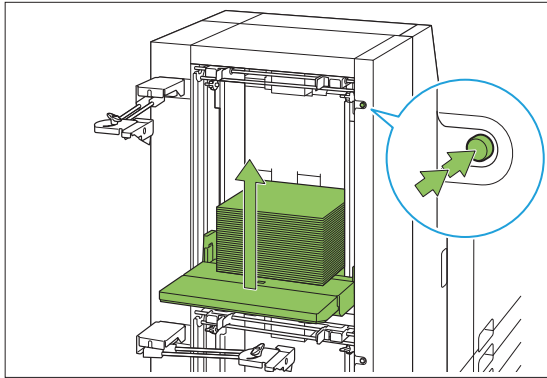

7 Adjust the paper feed guide (end) so that it is suitable for the paper size.

Adjust the paper feed guide (end) to match the guide against the edge of the paper, and turn the knob clockwise to fix the guide in position.

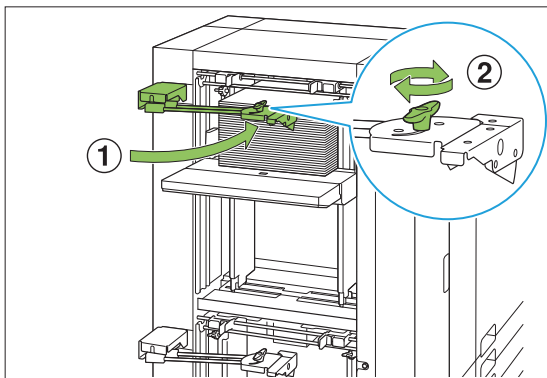

8 Adjust the side air adjustment levers (both sides).

For general use, set to "NORMAL". For thick paper and special paper, set to "CARD".

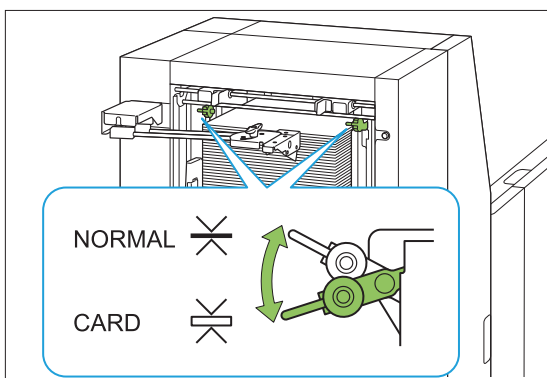

9 On the operation panel of printer 1, check [Paper Tray Setting].

Configure the paper size and type with [Paper Tray Setting]. (p.21 "Changing the Paper Tray Setting")
When changing the paper loaded in a tray, be sure to change the settings in [Paper Tray Setting].

■ Regarding the Feed Extension Plate

Attach the feed extension plate when loading paper with a length of 330 mm (13") or more in the upper paper feed tray.

! If the feed extension plate is not attached, loaded paper may hang down from the upper paper feed tray and paper jam may occur.

1 Attach the feed extension plate to the upper paper feed tray.

Insert into the upper feed extension shaft when attaching the extension plate.

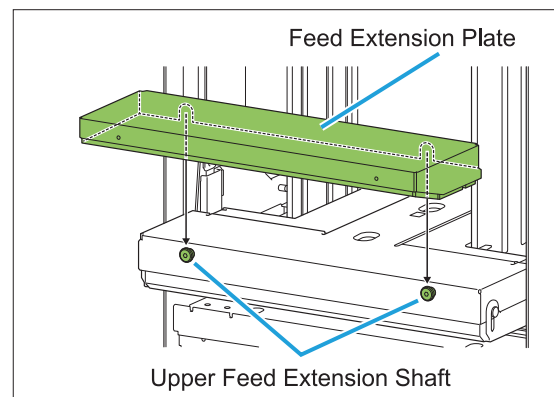

2 Attach the feed extension plate stoppers. (Thumbscrew M3x6; 4 pcs.)

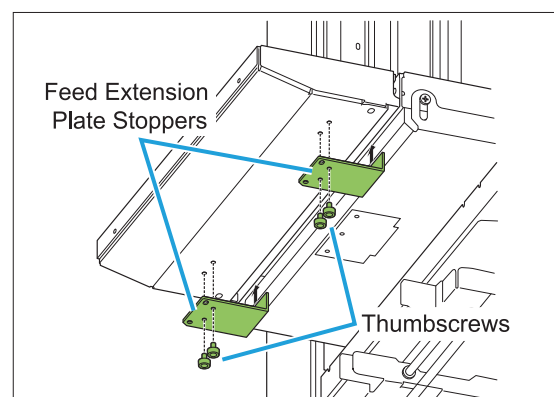

Adding the Paper

1 Spread the paper feed guide (end).

Turn the knob of the paper feed guide (end) counterclockwise to unlock and spread the guide.

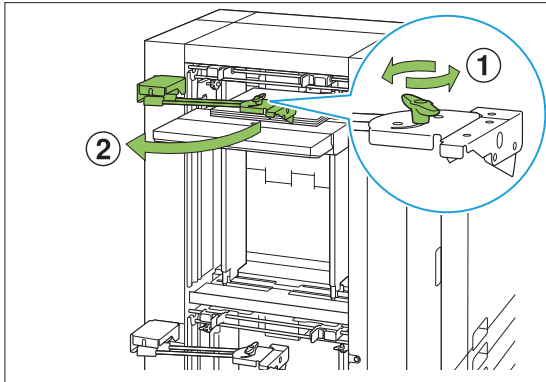

2 Press the standard tray descent button to lower the standard tray.

How the standard tray is lowered will differ depending on how the standard tray descent button is operated.

Hold down	The standard tray will keep lowering for as long as the button is being pressed. Hold the button down until the tray reaches the desired position.
Press and quickly release	The standard tray will be lowered to the position specified by the administrator.

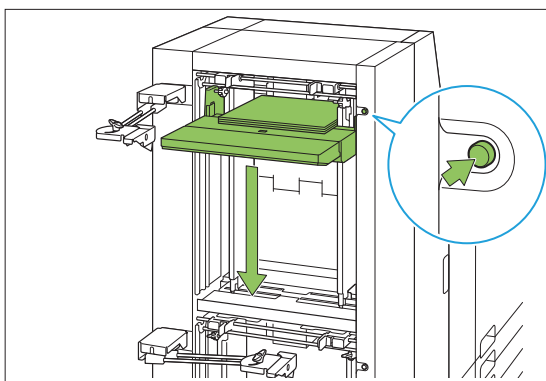

• The standard tray is also automatically lowered when all paper is removed.

- The position to which the standard tray is lowered when the standard tray descent button is pressed and quickly released or when paper runs out is set by the administrator. Contact your administrator for details.

3 Add the Paper.

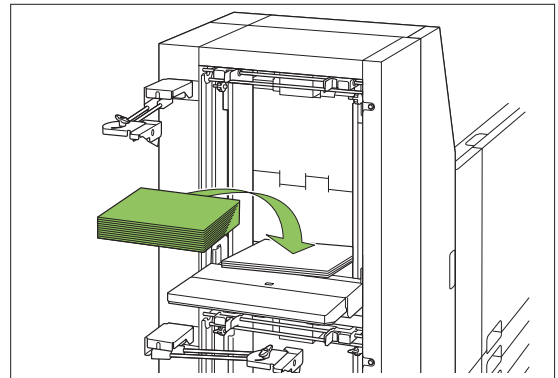

4 Press and quickly release the standard tray descent button twice.

5 Adjust the paper feed guide (end) so that it is suitable for the paper size.

Double Tray Stacker

Connecting the double tray stacker allows you to stack 8,000 sheets* of paper (4,000 sheets* for stacking trays of stacker 1 and stacker 2, respectively). The printouts that have been output can be removed at once with the dedicated carriage.

* When using plain paper, recycled paper (85 g/m² (23-lb bond))

- As seen from the front

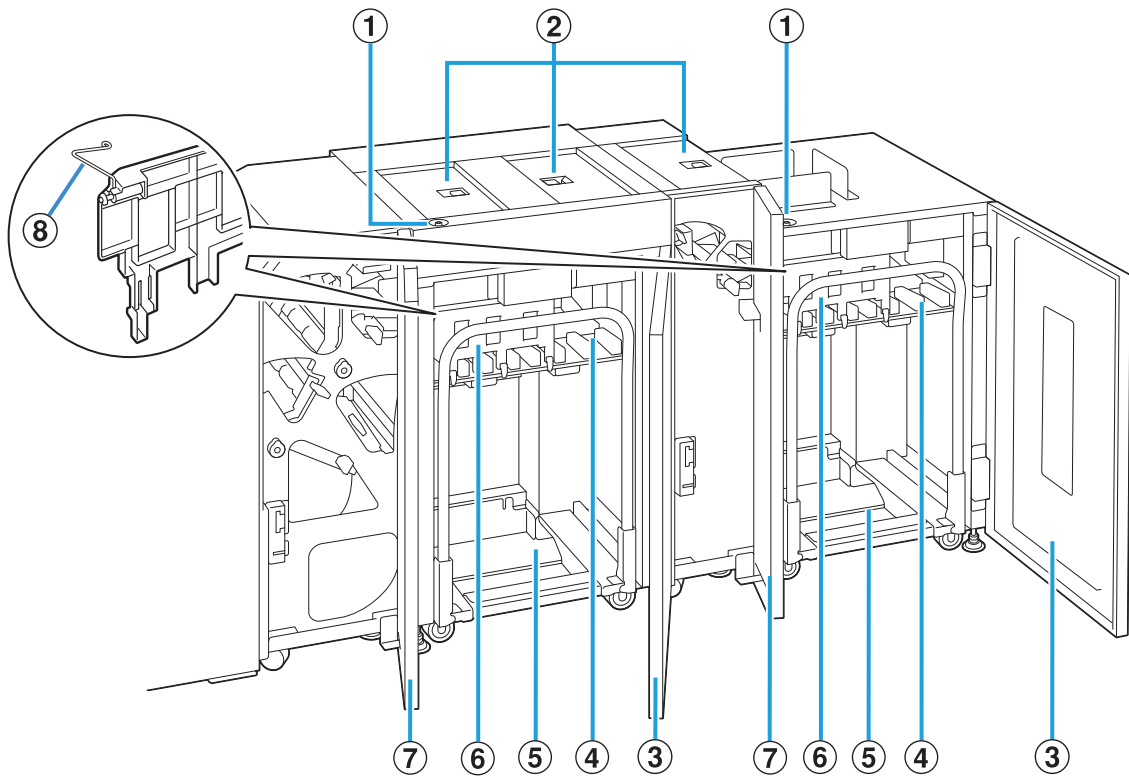

① Stacking Tray Descent Button

Press this button to remove printouts from the stacking tray. If you press the stacking tray descent button, the stacking tray lowers to the bottom (the position of the carriage). The stacking tray stops when you press the stacking tray descent button during lowering. If you press the button again, the stacking tray continues lowering. The stacking tray does not operate during printing even if you press the stacking tray descent button. Press with the right and left covers closed.

② Upper Transfer Cover

Open this cover when removing printouts, setting the carriage in position, or when removing paper jams.

③ Right Cover

Open this cover when removing printouts, setting the carriage in position, or when removing paper jams.

④ Stacking Tray

Printouts are output to this tray.

⑤ Carriage

Set this dedicated carriage inside the double tray stacker. Connect the stacking tray to the carriage to transport high-volume printouts.



- Be sure to use the dedicated carriage with the double tray stacker.

⑥ Paper Guide

Use this guide to prevent printouts that have been output from becoming misaligned.

⑦ Left Cover

If a paper jam occurs while paper is being transported, open this cover and remove the jammed paper.

⑧ Corrugators

Set the corrugators to feed paper smoothly according to the paper type and align printouts to stack neatly.

- As seen from the back

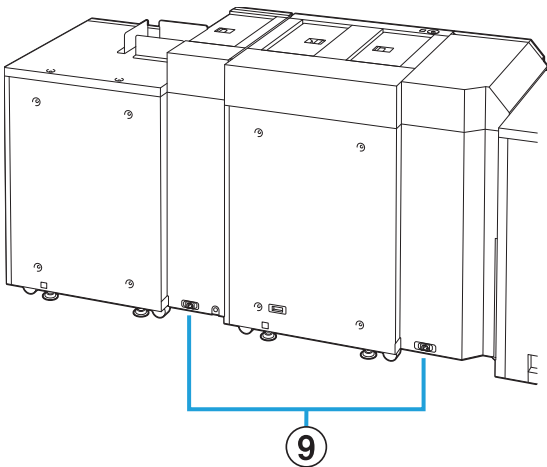

⑨ Double Tray Stacker Socket

Connect the double tray stacker power cord. The socket is located on the back of the double tray stacker.

Setting the Corrugators

As the state of paper transport and alignment will differ depending on the size or type of paper being used, adjust the corrugators so that the output and paper of printouts will be aligned.



- Normally, it will not be necessary to adjust the corrugators for printing. Adjust the corrugators for better feeding and printout alignment.
- Paper alignment may not improve according to the paper size, paper type, environment and storage. For more information, contact your dealer or authorized service representative.

■ Raising the Corrugators

Normally, the unit is used with the corrugators raised.

- 1 Lift the front corrugator while pressing it toward the machine (to the left).**

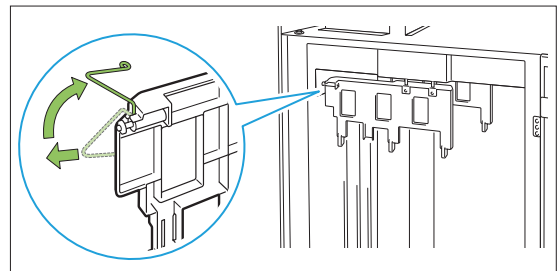

- 2 Similarly lift the back corrugator while pressing it toward the machine (to the left).**

■ Lowering the Corrugators

The unit is used with the corrugators lowered when printing on A3/B4/B5-LEF paper or thin paper.

- 1 Lower the front corrugator while pressing it toward the machine (to the left).

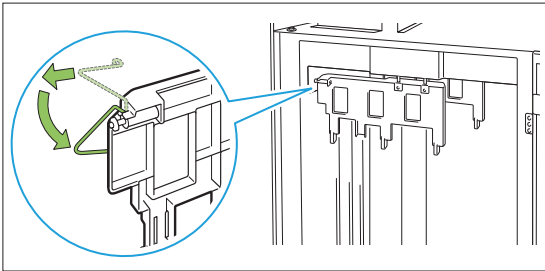

- 2 Similarly lower the back corrugator while pressing it toward the machine (to the left).

Removing Printouts

Remove printouts from the double tray stacker. There are two ways of removing the printouts.



- The printouts are to be removed when the stacking tray is at a full stop. A message indicating the status of the stacking tray is displayed on the operation panel. Follow the message.



- You can remove printouts by opening the right cover of the stacker that is not operated while the other stacker is operated.

- **When removing printouts with the carriage**
Remove printouts using the dedicated carriage for the double tray stacker.
- **When removing only the printouts**
Printouts can be removed without pulling out the dedicated carriage. You can remove printouts without waiting for the stacking tray to lower to the bottom.

■ When removing printouts with the carriage

- 1 Press the stacking tray descent button.

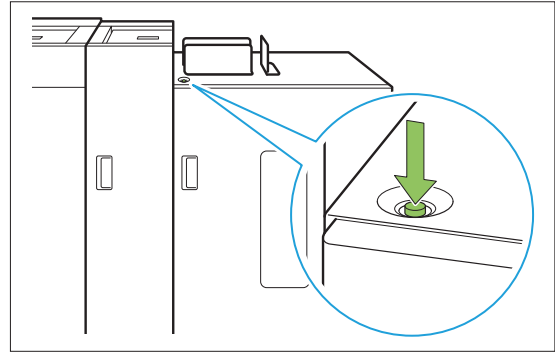

- Press the stacking tray descent button in a state where the covers on both sides of the stacker are closed. The stacking tray will not operate if the covers are open.
- The stacking tray will be automatically lowered to bottommost position after it outputs approximately 3,200 to 4,000 sheets of paper (at full capacity).
- Once printing has ended, the stacking tray will be automatically lowered to a position configured by the administrator. To change the position to which the stacking tray is lowered, contact your administrator.
- If you accidentally press the stacking tray descent button while printing, be sure to remove the printouts. In a state where printouts exist on the tray, the unit will not be capable of raising the stacking tray to the position for output.

- 2 Open the right cover of the double tray stacker.

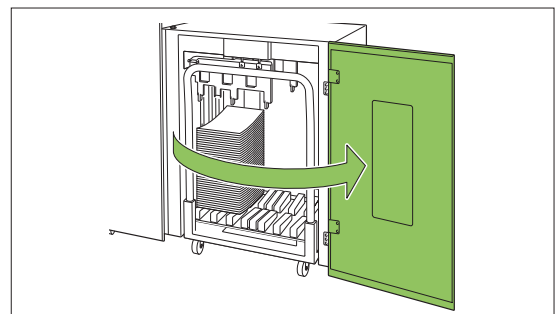

- 3 Pull out the carriage along with the stacking tray on it.



- Slowly pull out the carriage while holding its handle. Abruptly moving the cart may cause the printouts to collapse.

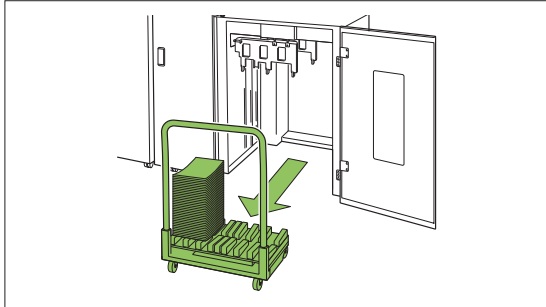

4 Remove printouts from the carriage.

5 Return the carriage to the double tray stacker.



- Be sure to return the carriage in a state where the stacking tray has been set.

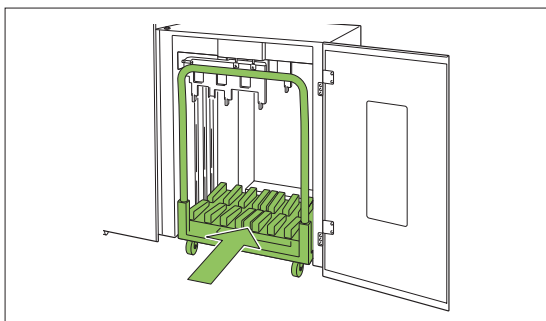

6 Close the right cover of the double tray stacker.

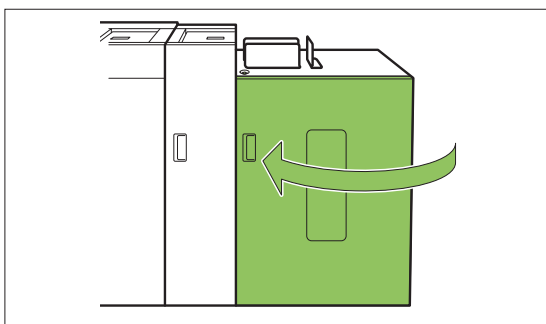

■ When Removing Only the Printouts

1 Open the right cover of the double tray stacker.

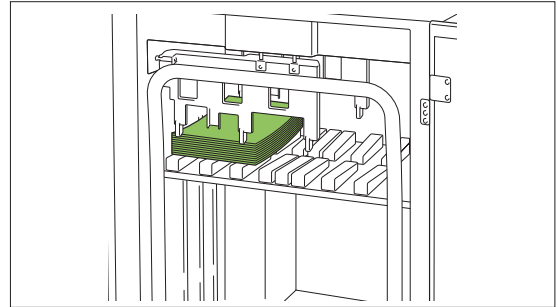

2 Remove the printouts.



- The position at which the stacking tray will stop is configured by the administrator. To change the position to which the tray is lowered, contact your administrator.
- Depending on the position at which the stacking tray will stop, the printouts may interfere with the guides making it difficult to be removed. In such case, close the right cover, press the stacking tray descent button, and remove the printouts after the stacking tray has been lowered.
- Depending on the size of the paper that has been output, the printouts may interfere with the handle of the carriage making it difficult to be removed. In such case, close the right cover, press the stacking tray descent button, and lower the stacking tray to the carriage. This will allow you to pull out the entire carriage and remove the paper.

3 Close the right cover of the double tray stacker.



- If the carriage has been pulled out in step 2, close the right cover after setting the carriage back into the double tray stacker.
- When configured so that the stacking tray is not lowered even after printing has ended, if there is paper on the stacking tray, the output guide is unable to move and may not be able to support the size of paper for the next job. Before printing jobs of different paper sizes, paper orientations, or paper tray settings, be sure to remove the paper on the stacking tray.

Setting the Stacking Tray on the Carriage

The stacking tray can be removed from the carriage. When you have removed the stacking tray to remove printouts, set the stacking tray on the carriage and return the double tray stacker together with the carriage.

- 1 Align the end of the stacking tray with the two screws at the base of the handle on the carriage.**

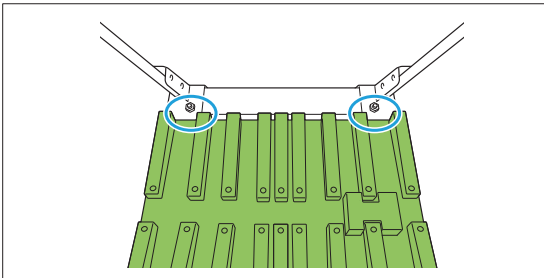

- 2 Set the carriage by inserting its protrusions into the holes in the stacking tray.**

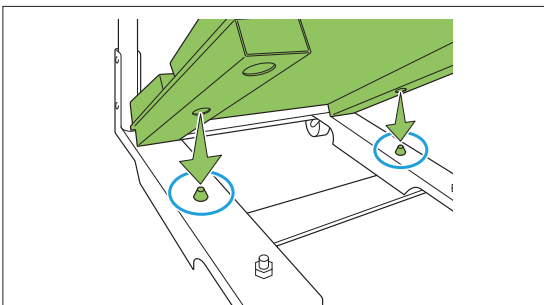

Maintenance Mode Settings

■ Paper Guide Control

Adjust the position of the paper guides. For more information, see "Paper Guide Control" (p.54) in the "Appendix".

■ Jogger Setting

Helps align printouts. For more information, see "Jogger Setting" (p.53) in the "Appendix".

Appendix

Maintenance

The following adjustments can be made in the [Maintenance] menu on the [Home] screen.

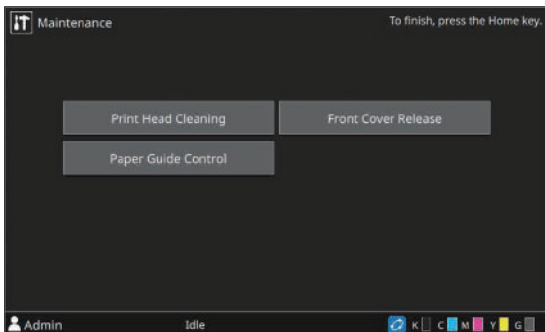

[Print Head Cleaning]

Cleans the ink head.

[Front Cover Release]

Releases the lock of the front cover on the machine.

[Jogger Setting]

Select whether to improve the alignment of printouts in the double tray stacker.

[Paper Guide Control]

Adjusts the position of the paper guides of the stacking tray.

Print Head Cleaning

Clean the ink head when you notice a change in image quality, such as blurring in part of a print, white streaking, or faded colors.



- By default, the unit is configured to automatically perform cleaning every time a certain number of printouts are made.

[Normal Cleaning]

Cleaning to prevent clogging of the ink heads.

[Strong Cleaning]

Strong cleaning performed when the ink head has clogged.

- 1 Touch [Maintenance] on the [Home] screen.

- 2 Touch [Print Head Cleaning].

The [Print Head Cleaning] screen is displayed.

- 3 Select the type of head cleaning.

- 4 Touch [OK].

Front Cover Release

Normally, the front cover of the machine is locked. The lock will be released in cases when it is necessary to open the front cover such as when paper has jammed or when ink has become empty. To open the front cover during regular operation, go to the [Maintenance] screen and touch [Front Cover Release]. The lock will be released and you will be able to open the front cover.

Once the cover has been closed, the lock will automatically engage as soon as operations start.

Jogger Setting

Vibrates the paper guides (side/end) of the double tray stacker to help align the edges of printouts.



- The paper guides (end) do not vibrate when printouts are stacked with offset.
- [Jogger Setting] cannot be changed during printing.

[OFF], [ON]

- 1 Touch [Maintenance] on the [Home] screen.

- 2 Touch [Jogger Setting].

The [Jogger Setting] screen is displayed.

- 3 Touch [ON].

- 4 Touch [OK].

Paper Guide Control

Adjusts the position of the paper guides of the stacking tray.

It is also possible to manually perform fine adjustments of the positions of the side guides and end guide.

[Auto]

The positions of the paper guides are automatically adjusted to suit the size of paper.

[Narrower]

The positions of the paper guides are narrowed by 1 mm (3/64") each towards the inner side of the stacker.

[Wider]

The positions of the paper guides are expanded by 1 mm (3/64") each towards the outer side of the stacker.



- Normally, use [Auto].

Manual Control of Paper Guide Control

You can expand or narrow the positions of the guides from their positions configured with [Auto]. You can individually adjust the positions of the side guides and end guide.

- 1 Touch [Maintenance] on the [Home] screen.
- 2 Touch [Paper Guide Control].
The [Paper Guide Control] screen is displayed.
- 3 Adjust the position of the paper guides.
 - To return the adjusted value to 0 mm, touch [Auto].
 - The adjusted value will also return to 0 mm when the [Power] key on the operation panel is pressed to restart the unit, the [Reset] key is pressed, or when the paper size has been changed.
- 4 Touch [Close].

About Ink Cartridges

Ink Cartridge Replacement

When ink runs out, the ink replacement message is displayed and printing stops. You cannot print if the message shows that even one color needs to be replaced. Replace the cartridge of the color shown.



- Do not remove the ink cartridge until the ink replacement message is displayed.



- When the remaining amount of ink is low, the remaining ink indicator on the touch panel screen flashes. Prepare a new ink cartridge for the color that flashes.

1 Open the front cover.

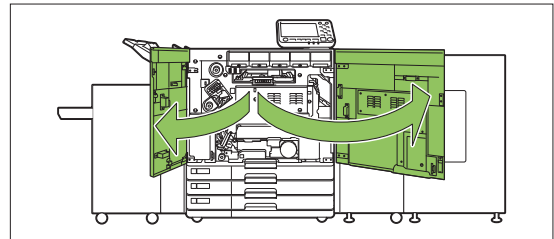

2 Remove the ink cartridge identified as empty.

Confirm the color of the ink cartridge.

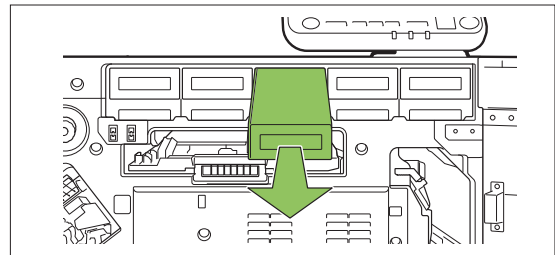

3 Remove the cap from the new ink cartridge.

Affix the removed cap on the old ink cartridge.

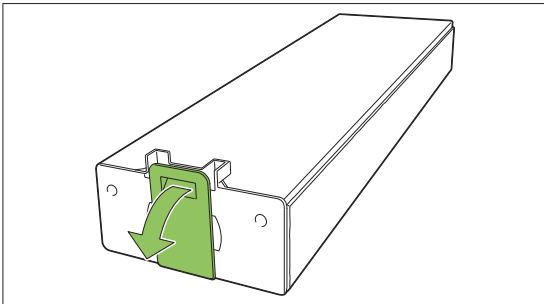

4 Insert the new ink cartridge.

Position the ink cartridge so that the ▲ mark faces upward, and insert it until it stops.

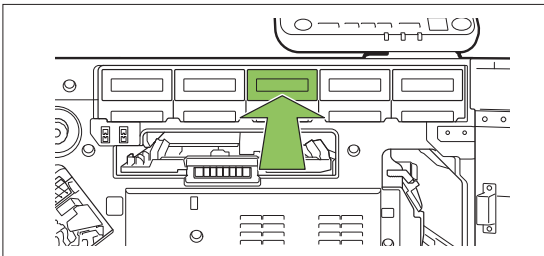

5 Close the front cover.

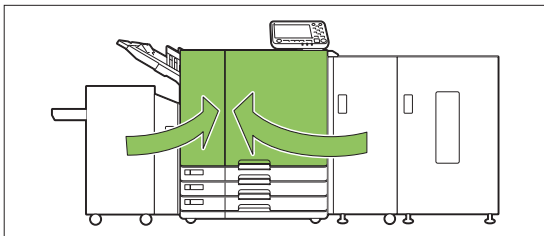

Specifications

■ VALEZUS T1200 Specifications

Basic Functions and Print Functions

Model: 68A01

Type	Console	
Color Support	5 colors (Cyan, Magenta, Yellow, Black, Gray)	
Print Type	Line-type inkjet system	
Ink Type	Oil-based pigment ink (Cyan, Magenta, Yellow, Black, Gray)	
Print Resolution	<p>Standard/High Chromogenic: Black: 600 dpi (main scanning direction) × 600 dpi (sub-scanning direction) Cyan, Magenta, Yellow, Gray: 300 dpi (main scanning direction) × 300 dpi (sub-scanning direction)</p> <p>Fine: Black: 600 dpi (main scanning direction) × 600 dpi (sub-scanning direction) Cyan, Magenta, Yellow, Gray: 300 dpi (main scanning direction) × 600 dpi (sub-scanning direction)</p>	
Number of Gray Levels	Black: 4 gray levels Cyan, Magenta, Yellow, Gray: 12 gray levels	
Data Processing Resolution	<p>Standard: Black: 600 dpi (main scanning direction) × 600 dpi (sub-scanning direction) Cyan, Magenta, Yellow, Gray: 300 dpi (main scanning direction) × 300 dpi (sub-scanning direction)</p> <p>High-definition: Black: 600 dpi (main scanning direction) × 600 dpi (sub-scanning direction) Cyan, Magenta, Yellow, Gray: 300 dpi (main scanning direction) × 600 dpi (sub-scanning direction)</p>	
Warm-up Time	2 min. 30 sec. or less (at room temperature of 23 °C (73.4 °F))	
First Print Time* ¹	When the high capacity feeder and high capacity stacker are connected: 8 sec. or less (A4-LEF* ⁶ Simplex)	
	When the double tray feeder and double tray stacker are connected: 14 sec. or less (A4-LEF* ⁶ Simplex)	
Continuous Print Speed* ²	A4-LEF* ⁶	Simplex: 165 ppm Duplex: 82 sheets/minute
	Letter-LEF	Simplex: 160 ppm Duplex: 80 sheets/minute
	A4	Simplex: 120 ppm Duplex: 60 sheets/minute
	Letter	Simplex: 120 ppm Duplex: 60 sheets/minute
	Legal	Simplex: 104 ppm Duplex: 44 sheets/minute
	JIS-B4	Simplex: 102 ppm Duplex: 44 sheets/minute
	A3	Simplex: 88 ppm Duplex: 42 sheets/minute
	Ledger	Simplex: 86 ppm Duplex: 42 sheets/minute
Paper Size	Feed Tray	Maximum: 297 mm × 432 mm (11 11/16" × 17") Minimum: 182 mm × 182 mm (7 3/16" × 7 3/16")

Printable Area		314 mm × 458 mm (12 11/32" x 18 1/32")
Guaranteed Print Area*3		Standard: Margin width of 3 mm (1/8") Maximum: Margin width of 1 mm (3/64")
Paper Weight	Feed Tray	52 g/m ² - 104 g/m ² (14-lb bond - 28-lb bond) (plain paper)
Paper Tray Capacity	Feed Tray	Height up to 56 mm (2 3/16") (3 trays)
Output Tray Capacity		Height up to 60 mm (2 11/32")
PDL (Page Description Language)		RISORINC/C IV
Supported Protocols		TCP/IP, HTTP, HTTPS (TLS), DHCP, ftp, lpr, IPP, SNMP (SNMP v1), Port 9100 (RAW port), IPv4, IPv6, IPsec (IKEv1)
Network Interface		Ethernet 1000BASE-T/100BASE-TX/10BASE-T (2ch)
Memory Capacity		4 GB
Solid State Drive *5	Capacity	512 GB
	Available Space	Approx. 370 GB
Operating System		Linux
Power Source	Rated Voltage	AC 100 V - 240 V
	Rated Frequency	50 Hz - 60 Hz
	Rated Current	When the high capacity feeder and high capacity stacker are connected: 14.4 A - 7.2 A
When the double tray feeder and double tray stacker are connected: 16.1 A - 8.1 A		
Power Consumption	When the high capacity feeder and high capacity stacker are connected:	
	<ul style="list-style-type: none"> • Max.: 1,440 W • Ready*4: 185 W or less • Sleep*7: 3 W or less • Stand-by: 1.4 W or less 	
Power Consumption	When the double tray feeder and double tray stacker are connected:	
	<ul style="list-style-type: none"> • Max.: 1,610 W • Ready*4: 245 W or less • Sleep*7: 3.5 W or less • Stand-by: 1.9 W or less 	
Operating Noise		Max. 68 dB (A) A4-LEF (Simplex) at the maximum print speed / Plain paper (64 g/m ² (17-lb bond))
Operating Environment		Temperature: 15 °C - 30 °C (59 °F - 86 °F) Humidity: 40% - 70% RH (non-condensing)

Dimensions (W × D × H)	Printer only: <ul style="list-style-type: none"> In use: 1,220 mm × 725 mm × 1,160 mm (48 1/32" × 28 17/32" × 45 21/32") With cover and tray closed: 1,160 mm × 705 mm × 1,015 mm (45 21/32" × 27 3/4" × 39 31/32")
	When the high capacity feeder and high capacity stacker are connected: <ul style="list-style-type: none"> In use: 2,545 mm × 725 mm × 1,160 mm (100 3/16" × 28 17/32" × 45 21/32") With cover and tray closed: 2,545 mm × 710 mm × 1,015 mm (100 3/16" × 27 15/16" × 39 31/32")
	When the double tray feeder and double tray stacker are connected: <ul style="list-style-type: none"> In use: 3,570 mm × 725 mm × 1,445 mm (140 9/16" × 28 17/32" × 56 7/8") With cover and tray closed: 3,570 mm × 710 mm × 1,445 mm (140 9/16" × 27 15/16" × 56 7/8")
Weight	Printer only: Approx. 167 kg (368 lb)
	When the high capacity feeder and high capacity stacker are connected: Approx. 378 kg (834 lb)
	When the double tray feeder and double tray stacker are connected: Approx. 622 kg (1,371 lb)
Safety Information	Indoor type, pollution degree 2*, At altitudes of 2,000 m or lower * The pollution degree of the usage environment due to dirt and dust in the air. Degree "2" corresponds to a general indoor environment.
Dimensions When Operating (W × D × H)*8	Printer only: 1,220 mm × 1,240 mm × 1,160 mm (48 1/32" × 48 13/16" × 45 21/32")
	When the high capacity feeder and high capacity stacker are connected: 2,555 mm × 1,315 mm × 1,160 mm (100 19/32" × 51 25/32" × 45 21/32")
	When the double tray feeder and double tray stacker are connected: 3,760 mm × 1,315 mm × 1,445 mm (148 1/32" × 51 25/32" × 56 7/8")

*1 Within 10 minutes after the last print job

*2 When using plain paper and recycled paper (85 g/m² (23-lb bond)), and standard density setting
Chart used: Print measurement pattern [Color measurement sample 2 (JEITA standard pattern J6)]

*3 The guaranteed area when printing images is the area enclosed within 3 mm (1/8") of the edges of the paper.
The margin when printing envelopes is 10 mm (13/32").

*4 Without printing and temperature adjustment operation

*5 One gigabyte (GB) is calculated as 1,073,741,824 bytes.

*6 LEF stands for "Long edge feed".

*7 When setting [Power Consumption (in Sleep)] to [Low]

*8 With the cover of each part open and the operation panel in the upright position.

Model: High Capacity Feeder G10

Type	External High Capacity Feeder
Paper Size	Maximum: 340 mm × 460 mm (13 3/8" × 18 1/8") Minimum: 90 mm × 148 mm (3 9/16" × 5 13/16")
Paper Type and Weight	46 g/m ² - 210 g/m ² (12-lb bond - 56-lb bond) (plain paper, recycled paper, envelopes, postcards)
Tray Capacity	Height up to 440 mm (17 5/16")
Power Source	AC 100 V - 240 V, 1.0 A - 0.5 A, 50 Hz - 60 Hz
Power Consumption	Max. 100 W
	Ready ^{*1} : 30 W or less
	Sleep ^{*2} : 0.5 W or less
	Stand-by: 0.5 W or less
Operating Noise	Max. 68 dB (A) A4-LEF (Simplex) at the maximum print speed
Dimensions (W × D × H)	790 mm × 630 mm × 740 mm (31 3/32" × 24 13/16" × 29 1/8")
Weight	Approx. 69 kg (152 lb)
Safety Information	Indoor type, pollution degree 2*, At altitudes of 2,000 m or lower * The pollution degree of the usage environment due to dirt and dust in the air. Degree "2" corresponds to a general indoor environment.

*1 Without printing operation

*2 When setting [Power Consumption (in Sleep)] to [Low]

Model: High Capacity Stacker G10

Type	High Capacity Stacker With Offset Function
Finishing Functions	Collating, stacking (offset)
Paper Size	Maximum: 340 mm × 460 mm (13 3/8" × 18 1/8") Minimum: 90 mm × 148 mm (3 9/16" × 5 13/16") Offset: 90 mm × 182 mm - 340 mm × 432 mm (3 9/16" × 7 3/16" - 13 3/8" × 17") (Envelopes are not acceptable.)
Paper Type and Weight	46 g/m ² - 210 g/m ² (12-lb bond - 56-lb bond) (plain paper, recycled paper, postcards)
Tray Capacity	Collating: Height up to 440 mm (17 5/16") ^{*1} Offset: Height up to 405 mm (15 15/16") ^{*2}
Power Source	AC 100 V - 240 V, 1.4 A - 0.7 A, 50 Hz - 60 Hz
Power Consumption	Max. 140 W
	Ready ^{*3} : 30 W or less
	Sleep ^{*4} : 0.5 W or less
	Stand-by: 0.5 W or less
Operating Noise	Max. 68 dB (A) A4-LEF (Simplex) at the maximum print speed
Dimensions (W × D × H)	1,000 mm × 700 mm × 960 mm (39 3/8" × 27 9/16" × 37 25/32")
Weight	Approx. 135 kg (298 lb)
Safety Information	Indoor type, pollution degree 2 [*] , At altitudes of 2,000 m or lower [*] The pollution degree of the usage environment due to dirt and dust in the air. Degree "2" corresponds to a general indoor environment.

*1 Height up to 110 mm (4 11/32") for A5, postcards, envelopes, non-regular size paper

*2 Not applicable to A5, postcards, envelopes, non-regular size paper, etc.

*3 Without printing operation

*4 When setting [Power Consumption (in Sleep)] to [Low]

Model: Double Tray Feeder

Type	External Double Tray Feeder Unit
Paper Size	148 mm × 210 mm - 330.2 mm × 460 mm (5 13/16" × 8 1/4" - 13" × 18 1/8")
Paper Type and Weight	46 g/m ² - 210 g/m ² (12-lb bond - 56-lb bond) (plain paper, recycled paper)
Tray Capacity	Height up to 440 mm (17 5/16") (2 trays)
Power Source	AC 100 V - 240 V, 1.8 A - 0.9 A, 50 Hz - 60 Hz
Power Consumption	Max. 180 W
	Ready ^{*1} : 40 W or less
	Sleep ^{*2} : 0.5 W or less
	Stand-by: 0.5 W or less
Operating Noise	Max. 68 dB (A) A4-LEF (Simplex/Duplex) at the maximum print speed
Dimensions (W × D × H)	940 mm × 630 mm × 1,445 mm (37" × 24 13/16" × 56 7/8")
Weight	Approx. 162 kg (357 lb)
Safety Information	Indoor type, pollution degree 2 [*] , At altitudes of 2,000 m or lower [*] The pollution degree of the usage environment due to dirt and dust in the air. Degree "2" corresponds to a general indoor environment.

*1 Without printing operation

*2 When setting [Power Consumption (in Sleep)] to [Low]

Model: Double Tray Stacker L/R

Type	Double Tray Stacker with the Offset Output Function
Paper Size	Without offset: 148 mm × 210 mm - 330.2 mm × 460 mm (5 13/16" × 8 1/4" - 13" × 18 1/8") Offset: 148 mm × 210 mm - 330.2 mm × 432 mm (5 13/16" × 8 1/4" - 13" × 17")
Paper Type and Weight	46 g/m ² - 210 g/m ² (12-lb bond - 56-lb bond) (plain paper, recycled paper)
Tray Capacity	Collating: Height up to 440 mm (17 5/16") ^{*1} (2 trays) Offset: Height up to 405 mm (15 15/16") ^{*2} (2 trays)
Power Source	AC 100 V - 240 V, 2.3 A - 1.2 A, 50 Hz - 60 Hz
Power Consumption	Max. 230 W
	Ready ^{*3} : 80 W or less
	Sleep ^{*4} : 1.0 W or less
	Stand-by: 1.0 W or less
Operating Noise	Max. 68 dB (A) A4-LEF (Simplex/Duplex) at the maximum print speed
Dimensions (W × D × H)	1,885 mm × 705 mm × 1,055 mm (74 7/32" × 27 3/4" × 41 17/32")
Weight	Approx. 281 kg (620 lb)
Safety Information	Indoor type, pollution degree 2 [*] , At altitudes of 2,000 m or lower [*] The pollution degree of the usage environment due to dirt and dust in the air. Degree "2" corresponds to a general indoor environment.

*1 Height up to 110 mm (4 11/32") for A5, non-regular size paper

*2 Not applicable to A5 or non-regular size paper

*3 Without printing operation

*4 When setting [Power Consumption (in Sleep)] to [Low]

Consumables

It is recommended that you use the consumable products listed below.
Consumable specifications and types are subject to change without notice.
For pricing information, please contact your dealer or authorized service representative.

Ink Cartridges

Type	Color	Quantity	Unit
VALEZUS Ink V2	Cyan Magenta Yellow Gray Black	NET. 1,000 ml	1 piece

Use the ink cartridge within approximately 24 months from the date of manufacture (when preserved under room temperature).
For optimal printing quality, we recommend that you use the ink cartridge as soon as possible after purchase.
You can find the date of manufacture on the ink cartridge.

VALEZUS T1200

Model: 68A01

Model: High Capacity Feeder G10

Model: High Capacity Stacker G10

Model: Double Tray Feeder

Model: Double Tray Stacker L/R

This Product Contains RFID (Radio Frequency Identification) System

Model: 050-34901

Contains FCC ID: RPARFR6

This device complies with Part 15 of the FCC Rules. Operation is subject to the following two conditions: (1) this device may not cause harmful interference, and (2) this device must accept any interference received, including interference that may cause undesired operation.

The user is cautioned that unauthorized changes or modifications not approved by RISO could void the user's authority to operate the equipment.

NOTE: This equipment has been tested and found to comply with the limits for a Class B digital device, pursuant to part 15 of the FCC Rules. These limits are designed to provide reasonable protection against harmful interference in a residential installation. This equipment generates, uses and can radiate radio frequency energy and, if not installed and used in accordance with the instructions, may cause harmful interference to radio communications. However, there is no guarantee that interference will not occur in a particular installation. If this equipment does cause harmful interference to radio or television reception, which can be determined by turning the equipment off and on, the user is encouraged to try to correct the interference by one or more of the following measures:

- Reorient or relocate the receiving antenna.
- Increase the separation between the equipment and receiver.
- Connect the equipment into an outlet on a circuit different from that to which the receiver is connected.
- Consult the dealer or an experienced radio / TV technician for help.

Contains IC: 4819A-RFR6

Operation is subject to the following two conditions: (1) this device may not cause interference, and (2) this device must accept any interference, including interference that may cause undesired operation of the device.

CAN ICES-3(B)/NMB-3(B)

Printers connected to the Double Tray Feeder and Double Tray Stacker L/R are Class B products. However, they are considered Class A products when used as the system (a series of equipment configurations including the printers connected to the Double Tray Feeder and Double Tray Stacker L/R).

NOTE: This equipment has been tested and found to comply with the limits for a Class A digital device, pursuant to part 15 of the FCC Rules. These limits are designed to provide reasonable protection against harmful interference when the equipment is operated in a commercial environment. This equipment generates, uses, and can radiate radio frequency energy and, if not installed and used in accordance with the instruction manual, may cause harmful interference to radio communications. Operation of this equipment in a residential area is likely to cause harmful interference in which case the user will be required to correct the interference at his own expense.

CAN ICES-3(A)/NMB-3(A)

Warning

This is a Class A product. In a domestic environment this product may cause radio interference in which case the user may be required to take adequate measures.

Perchlorate Material-special handling may apply,
See www.dtsc.ca.gov/hazardouswaste/perchlorate

This product may contain certain substances which are restricted when disposed. Therefore, be sure to consult your contracted service dealer.



RE directive Class1 device

Notice for European Union Member States

RISO, the environment and the Waste Electrical and Electronic Equipment Directive "WEEE Directive"

What is the WEEE Directive?

The purpose of the WEEE Directive is to reduce waste and ensure Electrical and Electronic Equipment is recycled at the end of its useful life.



What does the crossed out wheeled bin symbol mean?

The crossed out wheeled bin symbol indicates this product must be disposed of separately to normal waste. Please contact your RISO service agent for information about disposal.

What does the solid bar symbol mean?

The solid bar under the crossed out wheeled bin indicates this product was put on the market after the 13th August 2005.

Who should I contact if I want more information about the WEEE Directive?

You should contact your local RISO service agent for more information.

In order to promote proper recycling, we disclose the recycling system of used products and the packaging material information at the following URL.

<https://www.riso.co.jp/english/company/eco/performance/action/recycle.html>

Notice for Republic of India

RISO complies with the e-waste (Management and Handling) Rules "e-waste Rules".

What is the "e-waste Rules"?

The purpose of the "e-waste Rule" is to reduce waste and ensure Electrical Equipment is recycled at the end of life.

RISO declares our products comply with the "India E-waste Rule" and prohibits use of lead, mercury, hexavalent chromium, polybrominated biphenyls or polybrominated diphenyl ethers at or over a concentration of 0.1% by weight or at or over 0.01% by weight for cadmium, except for the exemptions set in Schedule 2 of the Rule.

You can't dispose of our used products as household waste. Used products contain many hazardous substances which may have a serious, detrimental effect on the environment and/or human health.

What does the crossed out wheeled bin symbol mean?

The crossed wheeled bin symbol indicates this product must be disposed of separately to household waste.



"e-waste Rules" shall apply to products including their components, consumables, parts and spares needed to function properly.

Who should I contact if I want more information about the "e-waste Rules"?

You should contact Riso India Pvt.Ltd.

Email: product-recycling@risoindia.com ; Tel : 0120-4721300



Please contact the following for supplies and service: